

datasheet

pco.edge 10 bi CLHS

the next-level sCMOS camera

bi back
illuminated

resolution
10.4 MPixel

pixel size
4.6 μm x 4.6 μm

interface
CLHS FOL



high dynamic range
14 000 : 1

high frame rate
122 fps

high resolution
4416 x 2368 pixels

low readout noise
0.7 e⁻ (med)

temperature-stabilized
image sensor

line scanning mode

technical data

image sensor			
	slow scan	medium scan	fast scan
sensor technology	back illuminated scientific CMOS (bi sCMOS)		
color type	monochrome		
resolution (horizontal x vertical)	4416 px x 2368 px		
pixel size (horizontal x vertical)	4.6 μm x 4.6 μm		
sensor size (horizontal x vertical)	20.3 mm x 10.8 mm		
sensor diagonal	23.0 mm		
shutter mode	rolling shutter (RS) additional feature: line scanning mode		
modulation transfer function (theoretical max.)	108.6 lp/mm		
peak quantum efficiency	85 % @ 500 nm		
spectral range	400 nm - 1100 nm		
dark current (typ.)	0.4 e ⁻ /pixel/s @ +10 °C sensor temperature		
fullwell capacity	625 e ⁻	14 000 e ⁻	18 000 e ⁻
readout noise (typ.) ¹	0.8 e ⁻ rms 0.7 e ⁻ med	1.2 e ⁻ rms 1.2 e ⁻ med	1.3 e ⁻ rms 1.3 e ⁻ med
dynamic range (intra-scene) ²	900 : 1 (59 dB)	12 000 : 1 (81 dB)	14 000 : 1 (83 dB)

¹ The readout noise values are given as median (med) and root mean square (rms) values, due to the different noise models which can be used for evaluation. All values are raw data without any filtering.

² The dynamic range value is calculated with the median value of the readout noise and rounded.

frame rate table			
vertical resolution reduction in fps			
	slow scan	medium scan	fast scan
4416 x 2368	30	61	122
4416 x 2048	35	70	141
4416 x 1024	70	140	281
4416 x 512	139	278	557
4416 x 256	274	549	1098
4416 x 128	533	1066	2132
4416 x 64	980	2014	4028
4416 x 32	980	3626	7252
4416 x 16	980	6043	12 086
4416 x 8	980	9065	18 130
typical resolutions in fps			
	slow scan	medium scan	fast scan
2304 x 2304	31	62	125
2048 x 2048	35	70	141
1920 x 1080	66	133	266
1280 x 1024	70	140	281
640 x 512	139	278	557
320 x 256	274	549	1098

camera

	slow scan	medium scan	fast scan
max. frame rate @ full resolution	30 fps	61 fps	122 fps
exposure time range	1 ms - 10 s	13.8 μ s - 10 s	6.9 μ s - 10 s
dynamic range A/D¹	11 bit		16 bit
conversion factor²	0.305 e ⁻ /DN	0.214 e ⁻ /DN	0.275 e ⁻ /DN
pixel rate	366 MPixel/s	733 MPixel/s	1467 MPixel/s
region of interest (ROI)		horizontal: steps of 32 columns vertical: steps of 4 rows	
binning		horizontal: x2, x4 (average, sum) vertical: x2, x4 (average, sum)	
non-linearity	< 0.5 %		< 0.2 %
dark signal non-uniformity (DSNU)	< 0.08 e ⁻ rms		< 0.23 e ⁻ rms
photo response non-uniformity (PRNU)	< 0.3 %		< 0.25 %
cooling temperature image sensor		adjustable: 0 °C to +25 °C calibration setpoint: +10 °C	
cooling method		forced air & liquid cooling	
trigger input signals		external exposure start, external exposure control, acquire enable	
status output signals		exposure, busy, line	
input / output signal connectors		SMA	
time stamp		in image (1 μ s resolution)	
data interface		Camera Link HS FOL	

¹ The high dynamic signal is simultaneously converted at high and low gain by two 11 bit A/D converters and the two 11 bit values are sophisticatedly merged into one 16 bit value.

² According to EMVA1288, the conversion factor equals the inverse of the system gain and can be operational mode dependent.

quantum efficiency

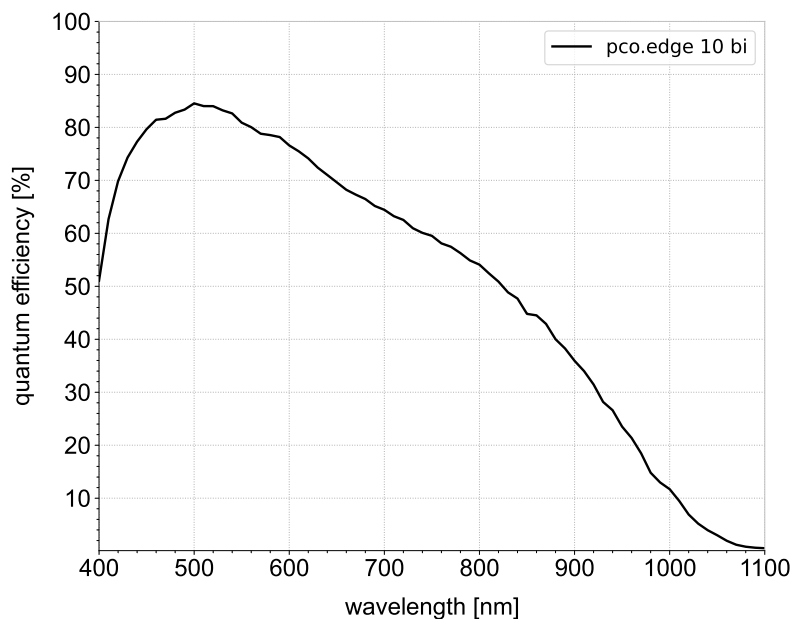

general

power supply	24 VDC (±10 %)
power consumption	max. 40 W
weight	1.35 kg
dimensions (height x width x length ¹)	95 mm x 90 mm x 109 mm
operating temperature range	+10 °C to +40 °C
storage temperature range	-10 °C to +60 °C
humidity range (non-condensing)	10 % to 80 % (recommended < 65 %)
certifications	CE, FCC, UKCA

¹ This value refers to the length including the camera flange.

optical interface

direct mounting distance (no camera flange)	6.2 mm (±10 %)
lens mounting	C-mount, F-mount
optional lens mounting	TFL-mount
optional lens remote control	EF-mount, EF-S-mount (Canon)

Configure your optical setup with our **MachVis Lens Selector** online tool.

dimensions

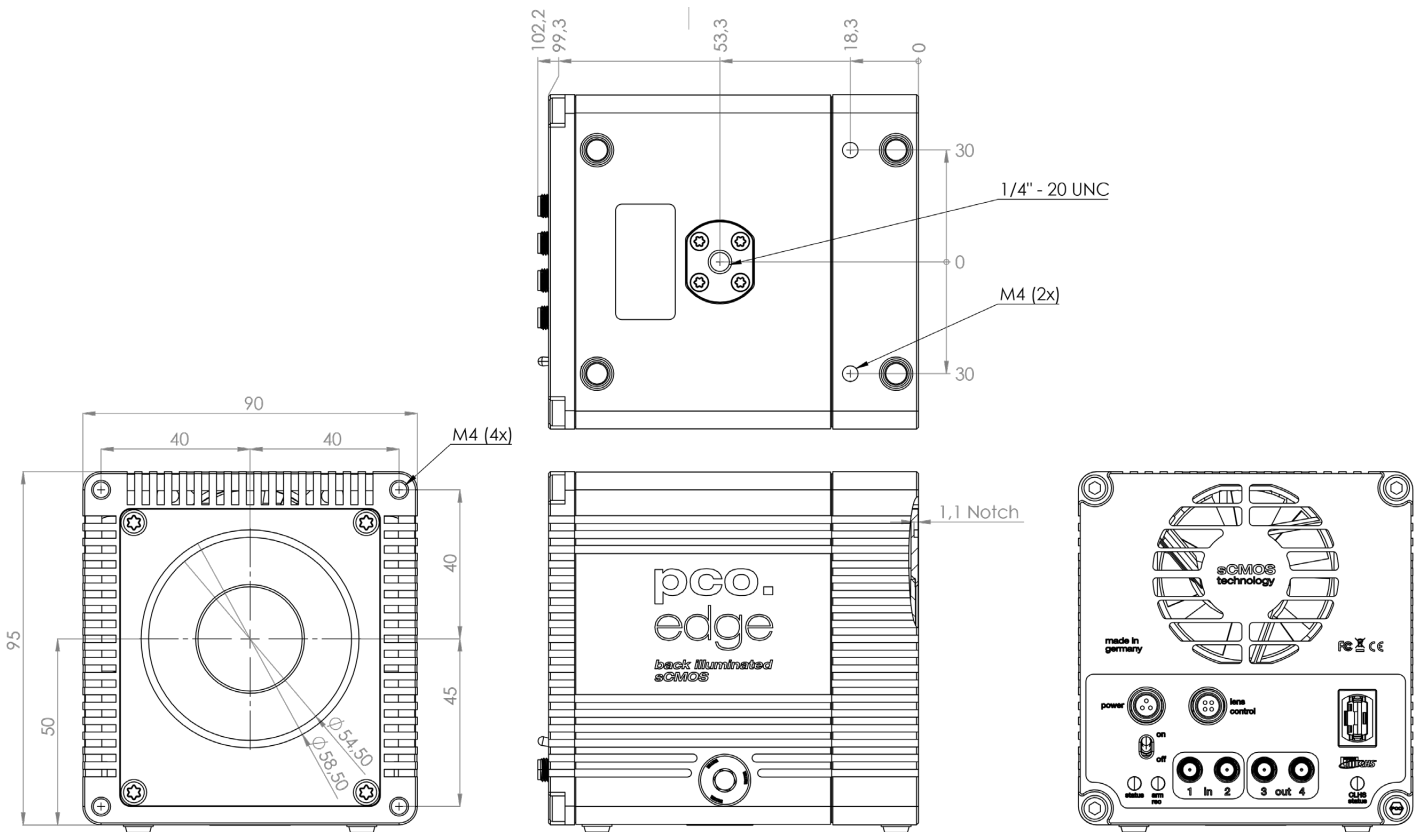

outlines of pco.edge 10 bi CLHS without camera flange (all dimensions given in mm)

line scanning mode

The line scanning mode is a special readout mode dedicated to lightsheet fluorescence microscopy (LSFM). Built on the rolling shutter mode, this feature enables optimized synchronization of the camera and the microscope system.

Unlike the standard rolling shutter mode, in which the only adjustable parameter is the exposure time, line scanning mode allows adjustment of two key parameters: the number of exposure lines and the line time, setting the exposure time according to the relation:

$$\text{exposure time} = \text{number of exposure lines} \times \text{line time.}$$

Together, the number of exposure lines and line time control the slit characteristics—with the slit referring to the area of the sensor exposed at any given time. While the number of exposure lines defines the slit width, which corresponds to the height of the moving exposure window, the line time determines the slit speed.

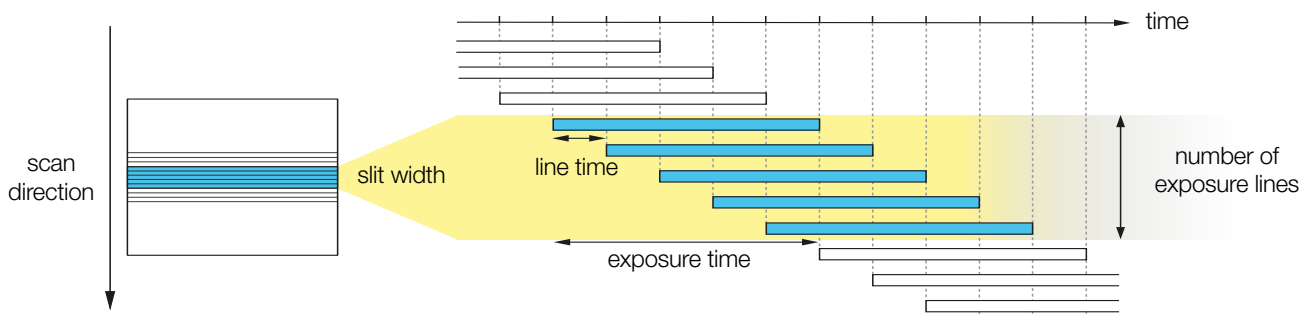

exemplary readout in line scanning mode with a slit width of five exposure lines

By synchronizing the slit with the focused excitation of the lightsheet, the impact of scattered light is minimized. Additionally, the fast scan rates, high sensitivity, low readout noise, and high dynamic range of the line scanning mode enhance the benefits of LSFM.

As LSFM reduces the risk of sample damage and photobleaching while enabling 3D imaging with minimal phototoxicity, it is ideal for live-cell imaging, in vivo studies, and dynamic biological processes.

software

Your first choice is pco.camware:

Our main camera control software enables control of most camera settings and facilitates image acquisition and storage.

You can customize it exactly to your needs using different layouts, styles and features.

You prefer to use a different software:

Our cameras integrate with a range of third-party software applications.

In microscopy we offer dedicated support for μ Manager, while ensuring compatibility with other software maintained by their providers.

You want to create your own application:

We feature a wide range of software development kits (SDK) for various programming languages, such as C++, Python, C#, LabVIEW, Matlab, and Java.

If you are looking for more general SDKs, we present pco.sdk and pco.recorder, our low-level SDKs with C interface.

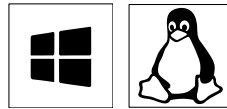
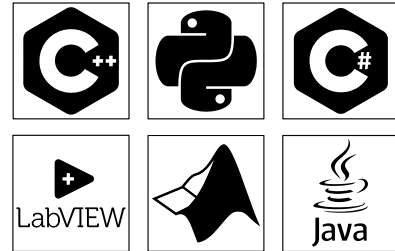

Our software is available for Windows and Linux platforms.

Visit our **website** for detailed information, installation guidance, and Github projects.

areas of application

3D metrology | biochip reading | biometrics | brightfield microscopy | calcium imaging | digital pathology | fluorescence microscopy | fluorescence recovery after photobleaching (FRAP) | Förster resonance energy transfer (FRET) | high-speed brightfield ratio imaging | high-throughput screening | image intensifier imaging | in vivo microscopy | industrial quality inspection | intravital microscopy | lightsheet fluorescence microscopy (LSFM) | material testing | ophthalmology | raman spectroscopy | selective plane illumination microscopy (SPIM) | single molecule localization microscopy (SMLM) – PALM, STORM, dSTORM, GSDIM | structured illumination microscopy (SIM) | total internal reflection fluorescence microscopy (TIRF) | wafer inspection

ordering information

pco.edge 10 bi CLHS

85108076021

camera system, 4432 x 2368 pixel, monochrome, back illuminated, rolling shutter, fast/medium/low-noise scan mode, CLHS interface, air & liquid cooling

pco.[®]

address: Excelitas PCO GmbH
Donaupark 11
93309 Kelheim, Germany

phone: (+49) 9441-2005-0
(+1) 866-662-6653
(+86) 0512-6763-4643

mail: pco@excelitas.com

web: www.excelitas.com/pco



excelitas.com

**excelitas**[®]