

datasheet

pco.edge 4.2 bi USB

pco.edge 4.2 bi UV USB

cooled sCMOS camera

bi back illuminated

UV ultraviolet*

resolution
4.2 MPixel

pixel size
6.5 μm x 6.5 μm

interface
USB 3.1 Gen 1



low light mode

line scanning mode

resolution
2048 x 2048 pixels

quantum efficiency
up to 95 %

ultraviolet variant
available*

deep cooled
down to -25 °C

technical data

image sensor

	standard mode	low light mode
sensor technology	back illuminated scientific CMOS (bi sCMOS)	
color type	monochrome	
resolution (horizontal x vertical)	2048 px x 2048 px	
pixel size (horizontal x vertical)	6.5 μm x 6.5 μm	
sensor size (horizontal x vertical)	13.3 mm x 13.3 mm	
sensor diagonal	18.8 mm	
shutter mode	rolling shutter (RS) global reset (GR) additional feature: line scanning mode	
modulation transfer function (theoretical max.)	76.9 lp/mm	
peak quantum efficiency	UV variant:	95 % @ 580 nm 89 % @ 580 nm 48 % @ 240 nm
spectral range	UV variant:	370 nm - 1100 nm 190 nm - 1100 nm
dark current (typ.)	0.2 e ⁻ /pixel/s @ -25 °C sensor temperature	
fullwell capacity	48 000 e ⁻	1800 e ⁻
readout noise (typ.)¹	1.9 e ⁻ rms 1.8 e ⁻ med	1.1 e ⁻ rms 1.0 e ⁻ med
dynamic range (intra-scene)²	26 500 : 1 (89 dB)	1800 : 1 (65 dB)

¹ The readout noise values are given as median (med) and root mean square (rms) values, due to the different noise models which can be used for evaluation. All values are raw data without any filtering.

² The dynamic range value is calculated with the median value of the readout noise and rounded.

frame rate table

vertical resolution reduction

2048 x 2048	40 fps
2048 x 1024	80 fps
2048 x 512	159 fps
2048 x 256	302 fps
2048 x 128	527 fps

typical resolutions

1920 x 1080	76 fps
1600 x 1200	68 fps
1280 x 1024	80 fps
640 x 480	171 fps
320 x 240	320 fps

camera	standard mode	low light mode
max. frame rate @ full resolution	40 fps	
exposure time range	21 μ s - 20 s	
dynamic range A/D ¹	16 bit	
conversion factor ²	0.7 e ⁻ /DN	0.03 e ⁻ /DN
pixel rate	184 MPixel/s	
region of interest (ROI)	horizontal: steps of 8 columns (min. 32) vertical: steps of 1 row (min. 8)	
binning	horizontal: x2, x4 (sum) vertical: x2, x4 (sum)	
non-linearity	< 0.6 %	
dark signal non-uniformity (DSNU)	< 0.6 e ⁻ rms	< 0.4 e ⁻ rms
photo response non-uniformity (PRNU)	< 1.2 %	< 1.4 %
cooling temperature image sensor	adjustable: -25 °C to +20 °C calibration setpoint: -10 °C	
cooling method	forced air & liquid cooling	
trigger input signals	external exposure start, external exposure control, sequence trigger, acquire enable	
status output signals	exposure, busy, line	
input / output signal connectors	SMA	
time stamp	in image (1 μ s resolution)	
data interface	USB 3.1 Gen 1	

¹ The high dynamic signal is simultaneously converted at high and low gain by two 12 bit A/D converters and the two 12 bit values are sophisticatedly merged into one 16 bit value.

² According to EMVA1288, the conversion factor equals the inverse of the system gain and can be operational mode dependent.

quantum efficiency

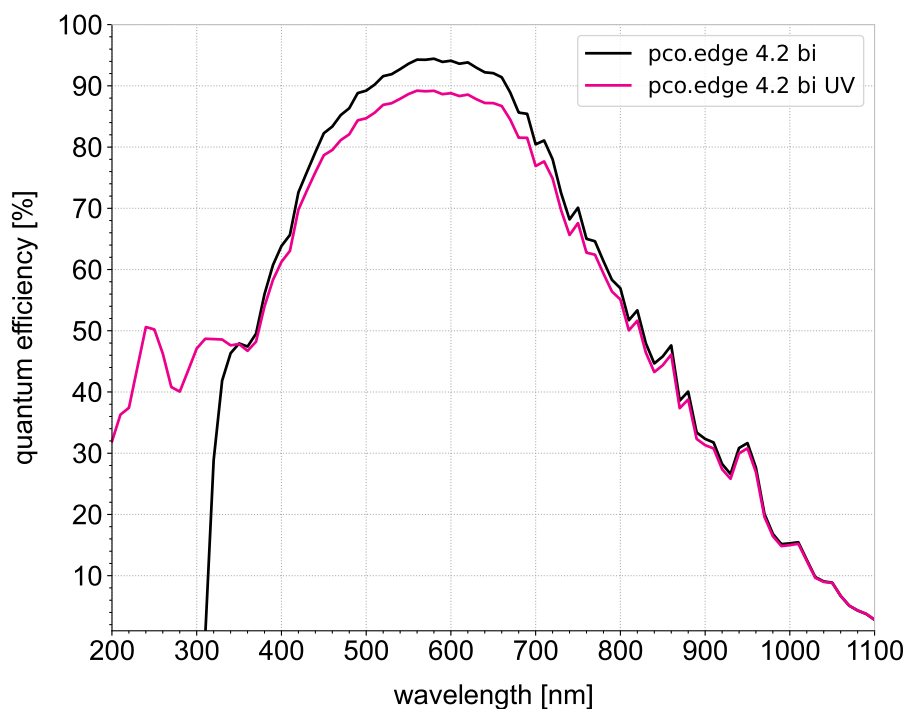

general

power supply	power over USB 3.1 Gen 1 and power connector (24 VDC \pm 10 %)
power consumption	max. 6 W over USB 3.1 Gen 1 and max. 22 W over power connector
weight	1.0 kg
dimensions (height x width x length¹)	85 mm x 80 mm x 109 mm
operating temperature range	+10 °C to +40 °C
storage temperature range	-10 °C to +60 °C
humidity range (non-condensing)	10 % to 80 % (recommended < 65 %)
certifications	CE, FCC, UKCA, KC

¹ This value refers to the length including the camera flange.

optical interface

selectable input window	visible UV 1°-wedge UV others on request
direct mounting distance (no camera flange)	6.2 mm (\pm 10 %)
lens mounting	C-mount, F-mount
optional lens mounting	TFL-mount
optional lens remote control	EF-mount, EF-S-mount (Canon)

Configure your optical setup with our **MachVis Lens Selector** online tool.

dimensions

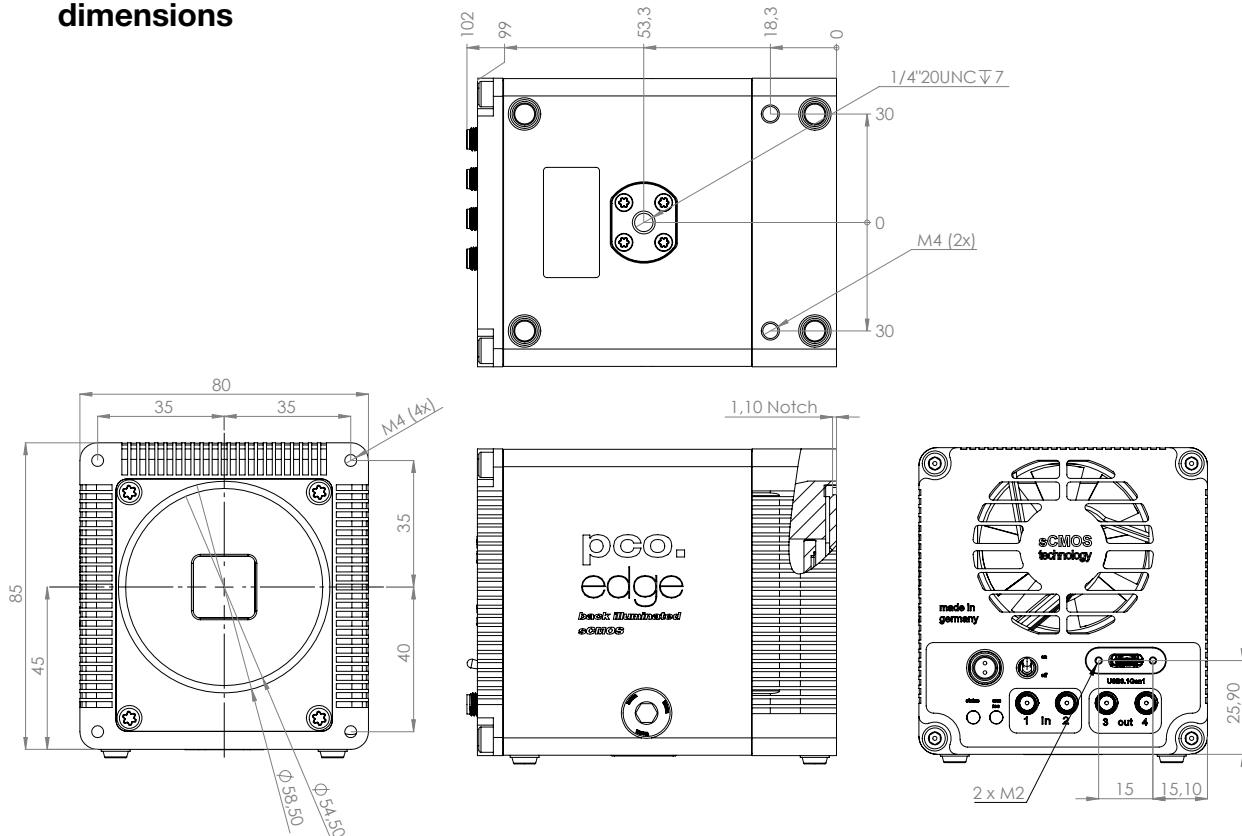

outlines of pco.edge 4.2 bi (UV) USB without camera flange (all dimensions given in mm)

low light mode

In standard mode two images with different gains are recorded in parallel. The low-gain image is optimized for high fullwell capacity, while the high-gain image is optimized for low readout noise. Both images are merged to create a high dynamic range image.



In low light mode two high-gain images are recorded simultaneously. It utilizes twofold correlated multi-sampling of high-gain images, reducing temporal noise by a factor of the square root of 2. This is ideal for applications that require low noise and high sensitivity.



line scanning mode

The line scanning mode is a special readout mode dedicated to lightsheet fluorescence microscopy (LSFM). Built on the rolling shutter mode, this feature enables optimized synchronization of the camera and the microscope system.

Unlike the standard rolling shutter mode, line scanning mode allows adjustment of two key parameters: the number of exposure lines and the line time. The number of exposure lines defines the slit width, while the line time determines the slit speed.

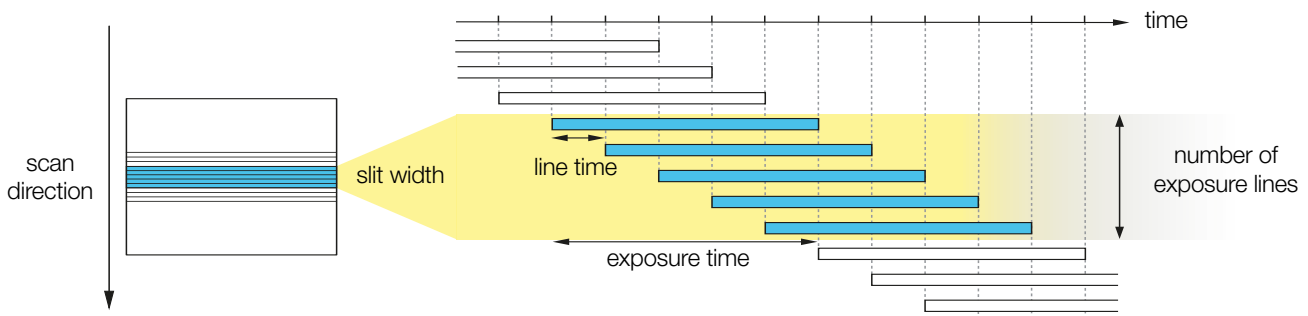

exemplary readout in line scanning mode with a slit width of five exposure lines

UV variant: 1°-wedge window

For specialized UV imaging applications, for example monitoring high-resolution photolithography during microchip manufacturing, we offer a dedicated camera variant.

This variant includes a high-purity fused silica cover glass with a 1°-wedge, as well as anti-reflective coating optimized for illumination around 200 nm. This ensures suppression of unwanted interferences when using coherent UV light - typically 193 nm irradiation from ArF laser systems.

software

Your first choice is pco.camware:

Our main camera control software enables control of most camera settings and facilitates image acquisition and storage.

You can customize it exactly to your needs using different layouts, styles and features.

You prefer to use a different software:

Our cameras integrate with a range of third-party software applications.

In microscopy we offer dedicated support for μ Manager, while ensuring compatibility with other software maintained by their providers.

You want to create your own application:

We feature a wide range of software development kits (SDK) for various programming languages, such as C++, Python, C#, LabVIEW, Matlab, and Java.

If you are looking for more general SDKs, we present pco.sdk and pco.recorder, our low-level SDKs with C interface.

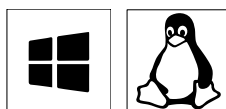
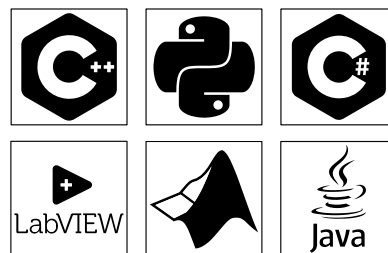

Our software is available for Windows and Linux platforms.

Visit our **website** for detailed information, installation guidance, and Github projects.

areas of application

3D metrology | bio luminescence | biochip reading | brightfield microscopy | calcium imaging | chemo luminescence | digital pathology | fluorescence microscopy | fluorescence recovery after photobleaching (FRAP) | Förster resonance energy transfer (FRET) | high-content screening | high-throughput screening | high-speed brightfield ratio imaging | industrial quality inspection | lightsheet fluorescence microscopy (LSFM) | lucky astronomy | ophthalmology | photovoltaic inspection | single molecule localization microscopy (SMLM) – PALM, STORM, dSTORM, GSDIM | spinning disk confocal microscopy | structured illumination microscopy (SIM) | total internal reflection fluorescence microscopy (TIRF) | UV imaging

ordering information

pco.edge 4.2 bi USB	85108075010	camera system, 2048 x 2048 pixel, monochrome, back illuminated, rolling shutter, USB 3.1 interface, air & liquid cooling
pco.edge 4.2 bi UV USB	85108075013	camera system, 2048 x 2048 pixel, monochrome, back illuminated, rolling shutter, UV+ input window, USB 3.1 interface, air & liquid cooling
pco.edge 4.2 bi UV KG1 USB	85108075021	camera system, 2048 x 2048 pixel, monochrome, back illuminated, rolling shutter, 1°-wedge input window (optimized for UV illumination around 200 nm), USB 3.1 interface, air & liquid cooling

address: Excelitas PCO GmbH
Donaupark 11
93309 Kelheim, Germany

phone: (+49) 9441-2005-0
(+1) 866-662-6653
(+86) 0512-6763-4643

mail: pco@excelitas.com

web: www.excelitas.com/pco

