

datasheet

# pco.edge 4.2 USB

cooled sCMOS camera

resolution  
**4.2 MPixel**

pixel size  
**6.5  $\mu\text{m}$  x 6.5  $\mu\text{m}$**

interface  
**USB 3.0**



low readout noise  
0.8 e<sup>-</sup> (med)

high resolution  
2048 x 2048 pixels

high speed  
40 fps

high dynamic range  
37 500 : 1

high quantum efficiency  
up to 80 %

## technical data

### image sensor

<b>sensor technology</b>	scientific CMOS (sCMOS)
<b>color type</b>	monochrome
<b>resolution (horizontal x vertical)</b>	2048 px x 2048 px
<b>pixel size (horizontal x vertical)</b>	6.5 $\mu\text{m}$ x 6.5 $\mu\text{m}$
<b>sensor size (horizontal x vertical)</b>	13.3 mm x 13.3 mm
<b>sensor diagonal</b>	18.8 mm
<b>shutter mode</b>	rolling shutter (RS) with selectable readout direction global reset (GR)
<b>modulation transfer function (theoretical max.)</b>	76.9 lp/mm
<b>peak quantum efficiency</b>	80 % @ 580 nm
<b>spectral range</b>	300 nm - 1100 nm
<b>dark current (typ.)</b>	0.3 e <sup>-</sup> /pixel/s @ 0 °C sensor temperature
<b>fullwell capacity</b>	30 000 e <sup>-</sup>
<b>readout noise (typ.)<sup>1</sup></b>	1.5 e <sup>-</sup> rms 0.8 e <sup>-</sup> med
<b>dynamic range (intra-scene)<sup>2</sup></b>	37 500 : 1 (91 dB)

<sup>1</sup> The readout noise values are given as median (med) and root mean square (rms) values, due to the different noise models which can be used for evaluation. All values are raw data without any filtering.

<sup>2</sup> The dynamic range value is calculated with the median value of the readout noise and rounded.

### frame rate table

#### vertical resolution reduction

<b>2048 x 2048</b>	40 fps
<b>2048 x 1024</b>	80 fps
<b>2048 x 512</b>	160 fps
<b>2048 x 256</b>	315 fps
<b>2048 x 128</b>	610 fps

#### typical resolutions

<b>1920 x 1080</b>	76 fps
<b>1600 x 1200</b>	69 fps
<b>1280 x 1024</b>	80 fps
<b>640 x 480</b>	170 fps
<b>320 x 240</b>	335 fps

**camera**

<b>max. frame rate @ full resolution</b>	40 fps
<b>exposure time range</b>	100 $\mu$ s - 20 s (RS) 30 $\mu$ s - 2 s (GR)
<b>dynamic range A/D<sup>1</sup></b>	16 bit
<b>conversion factor<sup>2</sup></b>	0.46 e <sup>-</sup> /DN
<b>pixel rate</b>	220 MPixel/s
<b>region of interest (ROI)</b>	horizontal: steps of 4 columns (min. 64) vertical: steps of 1 row (min. 16)
<b>binning</b>	horizontal: x2, x4 (sum) vertical: x2, x4 (sum)
<b>non-linearity</b>	< 0.6 %
<b>dark signal non-uniformity (DSNU)</b>	< 0.3 e <sup>-</sup> rms
<b>photo response non-uniformity (PRNU)</b>	< 0.2 %
<b>cooling temperature image sensor</b>	0 °C stabilized (up to +27 °C ambient temperature)
<b>cooling method</b>	forced air & liquid cooling
<b>trigger input signals</b>	external exposure start, external exposure control, sequence trigger, acquire enable
<b>status output signals</b>	exposure, busy, line
<b>input / output signal connectors</b>	SMA
<b>time stamp</b>	in image (1 $\mu$ s resolution)
<b>data interface</b>	USB 3.0

<sup>1</sup> The high dynamic signal is simultaneously converted at high and low gain by two 11 bit A/D converters and the two 11 bit values are sophistically merged into one 16 bit value.

<sup>2</sup> According to EMVA1288, the conversion factor equals the inverse of the system gain and can be operational mode dependent.

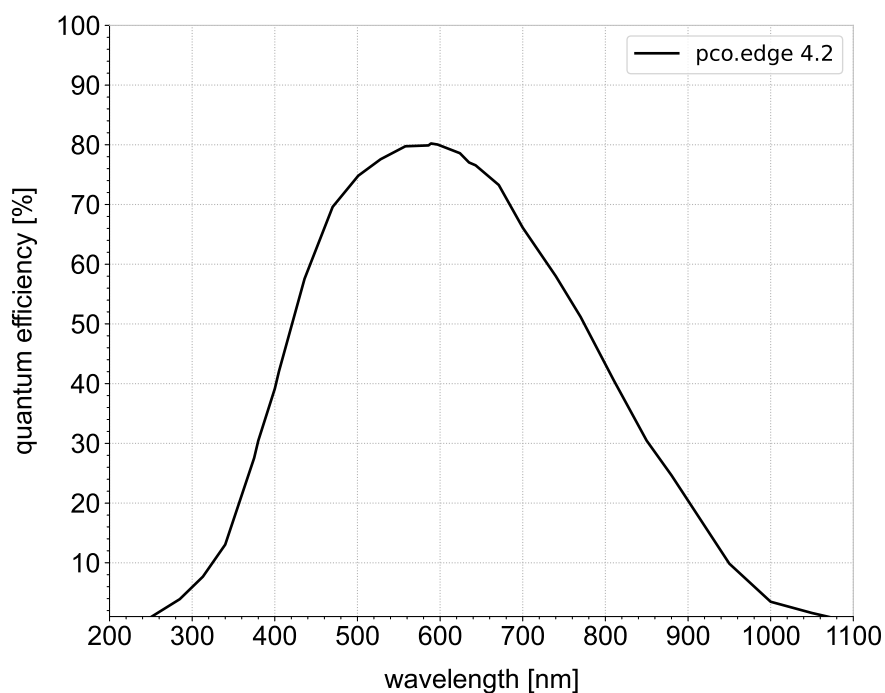
**quantum efficiency**

### general

power supply	24 VDC (±10 %)
power consumption	max. 21 W
weight	0.75 kg
dimensions (height x width x length)	76 mm x 70 mm x 99.5 mm
operating temperature range	+10 °C to +40 °C
storage temperature range	-10 °C to +60 °C
humidity range (non-condensing)	10 % to 80 % (recommended < 65 %)
certifications	CE, FCC, UKCA, KC

### optical interface

direct mounting distance	11.1 mm (±10 %)
lens mounting	C-mount, F-mount
optional lens mounting	TFL-mount

Configure your optical setup with our **MachVis Lens Selector** online tool.

### dimensions

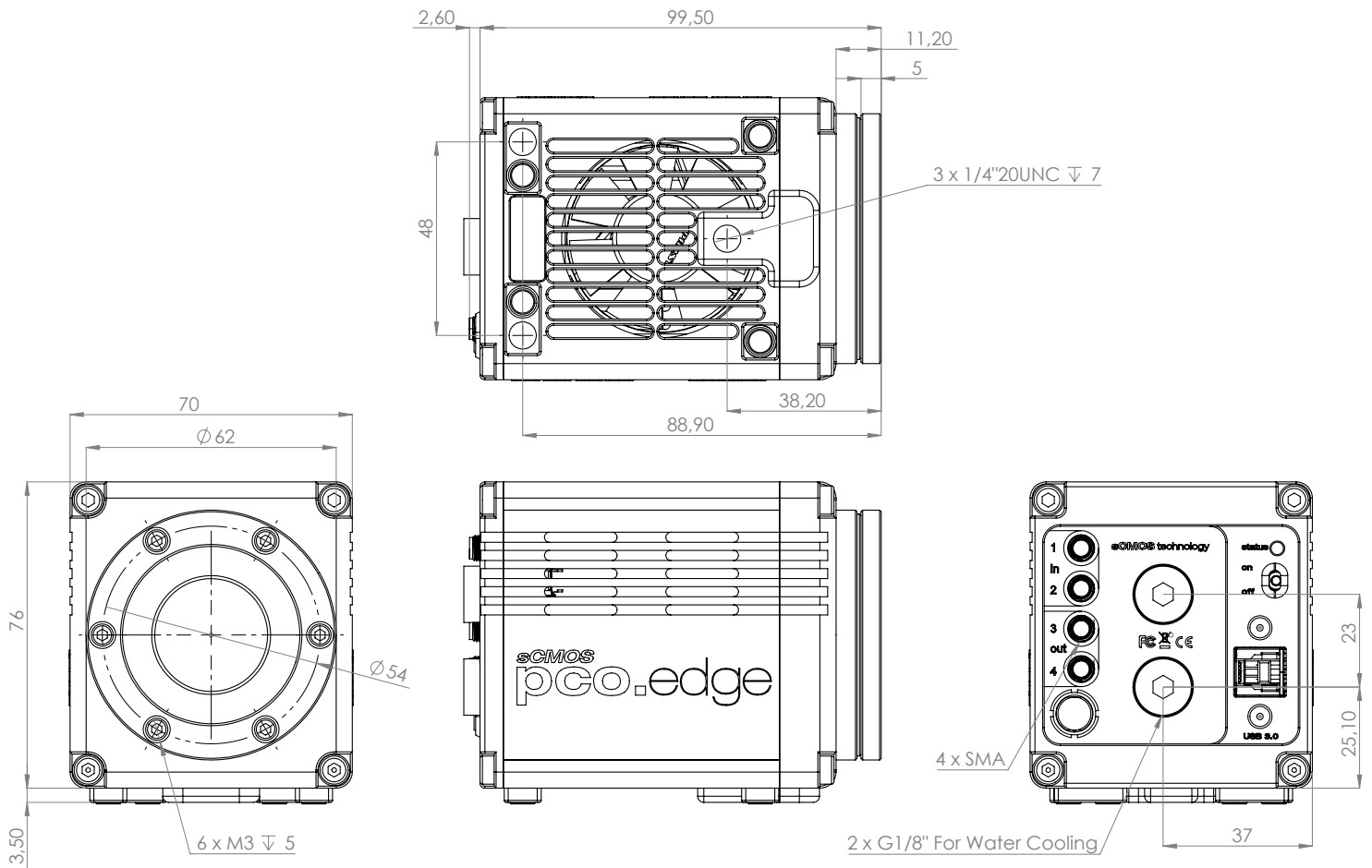

outlines of pco.edge 4.2 USB (all dimensions given in mm)

## software

### Your first choice is pco.camware:

Our main camera control software enables control of most camera settings and facilitates image acquisition and storage.

You can customize it exactly to your needs using different layouts, styles and features.

### You prefer to use a different software:

Our cameras integrate with a range of third-party software applications.

In microscopy we offer dedicated support for  $\mu$ Manager, while ensuring compatibility with other software maintained by their providers.

### You want to create your own application:

We feature a wide range of software development kits (SDK) for various programming languages, such as C++, Python, C#, LabVIEW, Matlab, and Java.

If you are looking for more general SDKs, we present pco.sdk and pco.recorder, our low-level SDKs with C interface.

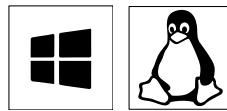
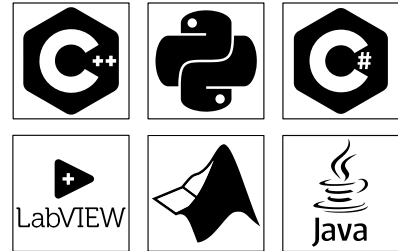

Our software is available for Windows and Linux platforms.

Visit our **website** for detailed information, installation guidance, and Github projects.

## areas of application

3D metrology | biochip reading | brightfield microscopy | calcium imaging | digital pathology | fluorescence microscopy | fluorescence recovery after photobleaching (FRAP) | Förster resonance energy transfer (FRET) | high-content screening | high-speed brightfield ratio imaging | high-throughput screening | image intensifier imaging | industrial quality inspection | lightsheet fluorescence microscopy (LSFM) | lucky astronomy | ophthalmology | photovoltaic inspection | single molecule localization microscopy (SMLM) – PALM, STORM, dSTORM, GSDIM | spinning disk confocal microscopy | structured illumination microscopy (SIM) | super-resolution microscopy | total internal reflection fluorescence microscopy (TIRF) | wafer inspection

## ordering information

pco.edge 4.2 USB

85108072513

camera system, 2048 x 2048 pixel, monochrome, rolling shutter, USB 3.0 interface, air & liquid cooling

**pco.**<sup>®</sup>

address: Excelitas PCO GmbH  
Donaupark 11  
93309 Kelheim, Germany

phone: (+49) 9441-2005-0  
(+1) 866-662-6653  
(+86) 0512-6763-4643

mail: [pco@excelitas.com](mailto:pco@excelitas.com)

web: [www.excelitas.com/pco](http://www.excelitas.com/pco)

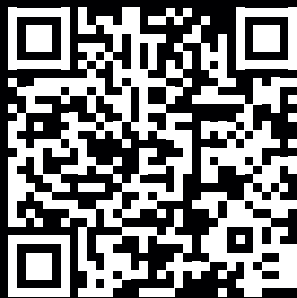

[excelitas.com](http://excelitas.com)

**excelitas**<sup>®</sup>