

Photodiode C30817EH series

Silicon Avalanche Photodiode for General-Purpose Applications

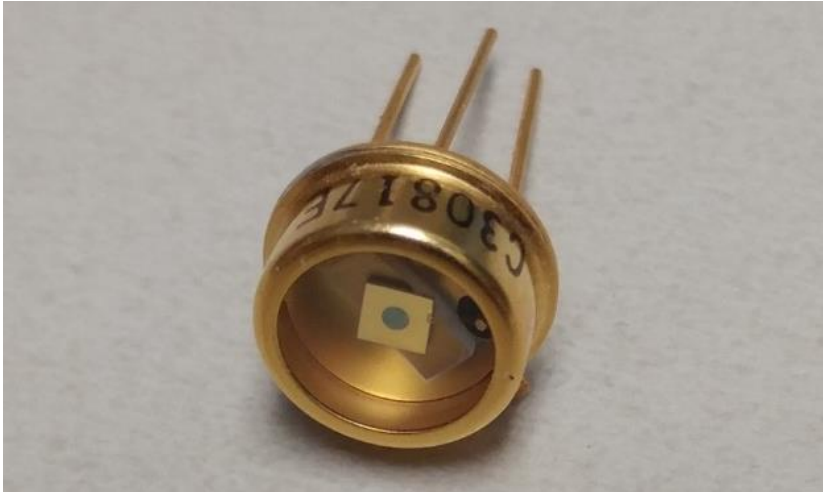

The C30817EH is a general-purpose silicon avalanche photodiode made using a double-diffused “reach through” structure. This structure provides high responsivity between 400 to 1100 nanometers as well as fast rise and fall times at all wavelengths. Because the fall time characteristics had no “tail”, the responsivity of the device is independent of modulation frequency up to about 200 MHz.

The C30817 is hermetically sealed behind a flat glass window in a modified low-profile TO-5 package.

The device is useful in a wide variety of applications including laser detection, ranging, optical communications, high-speed switch, and transit-time measurements.

Key Features

- High Quantum Efficiency
 - 85% typical at 900nm
 - 18% typical at 1060 nm
- Spectral Response range – 400 to 1100nm
- Fast Time Response
 - Rise time and Fall time typically 2ns
- Wide Operating Temperature Range

Applications

- Laser detection
- Ranging
- Optical communications
- High-speed switching
- Transit-time measurements

Photodiode C30817EH series
Silicon Avalanche Photodiode for General-Purpose Applications

Parameter	Symbol		Units	Remarks / Conditions
Package				TO-5
Photosensitive Surface: Useful area Useful diameter	A d	0.5 0.8	mm ² mm	Shape : Circular
Field of View: Nominal field of view α (see Figure 9) Nominal field of view α' (see Figure 9)	FoV	119 132	Degrees	

Table 2 – Electro-Optical Characteristics

Test conditions: Case temperature = 22°C, ; at the DC reverse operating voltage V_{op} supplied with device

Parameter	Symbol	Minimum	Typical	Maximum	Units
Breakage Voltage	V_{br}	300	375	475	V
Operating Voltage	V_{op}	275		425	
Temperature Coefficient of V_{op} for Constant Gain			2.2		V/°C
Gain	M		120		
Responsivity at 900 nm at 1060 nm	R	65 15	75 18		A/W
Quantum Efficiency: at 900 nm at 1060 nm	Q.E.		85 18		%
Total Dark Current	I_d		50	200	nA
Noise Current f = 10 kHz $\Delta f = 1$ Hz; See Figure 5	i_n		1.0	2.0	pA/√Hz
Capacitance	C_d		2	4	pF
Series Resistance	R_s			15	Ω
Rise/Fall Time, $R_L = 50\Omega$, $\lambda = 900$ nm: 10% to 90% points 90% to 10% points	t_r t_f		2	3	ns

Photodiode C30817EH series
Silicon Avalanche Photodiode for General-Purpose Applications

Table 3 – Absolute – Maximum Ratings, Limiting Values

Parameter	Symbol	Min.	Typ.	Max.	Units	Remarks / Conditions
Reverse Bias Dark Current				100	max. μA	
Photocurrent Density: average value peak value	J_p			5 20	mA/mm^2	At 22 °C ; Continuous operation
Forward Current: average value peak value	I_F			5 50	max. mA	For 1 second duration, non-repetitive
Maximum Total Power				0.1	W	Dissipation at 22 °C
Operating Temperature	T_o	-40		70	°C	
Storage Temperature	T_{stg}	-60		100	°C	
Soldering				200	°C	5 seconds, leads only

Figure 1 – Typical Spectral Responsivity Characteristic at a Gain of 120

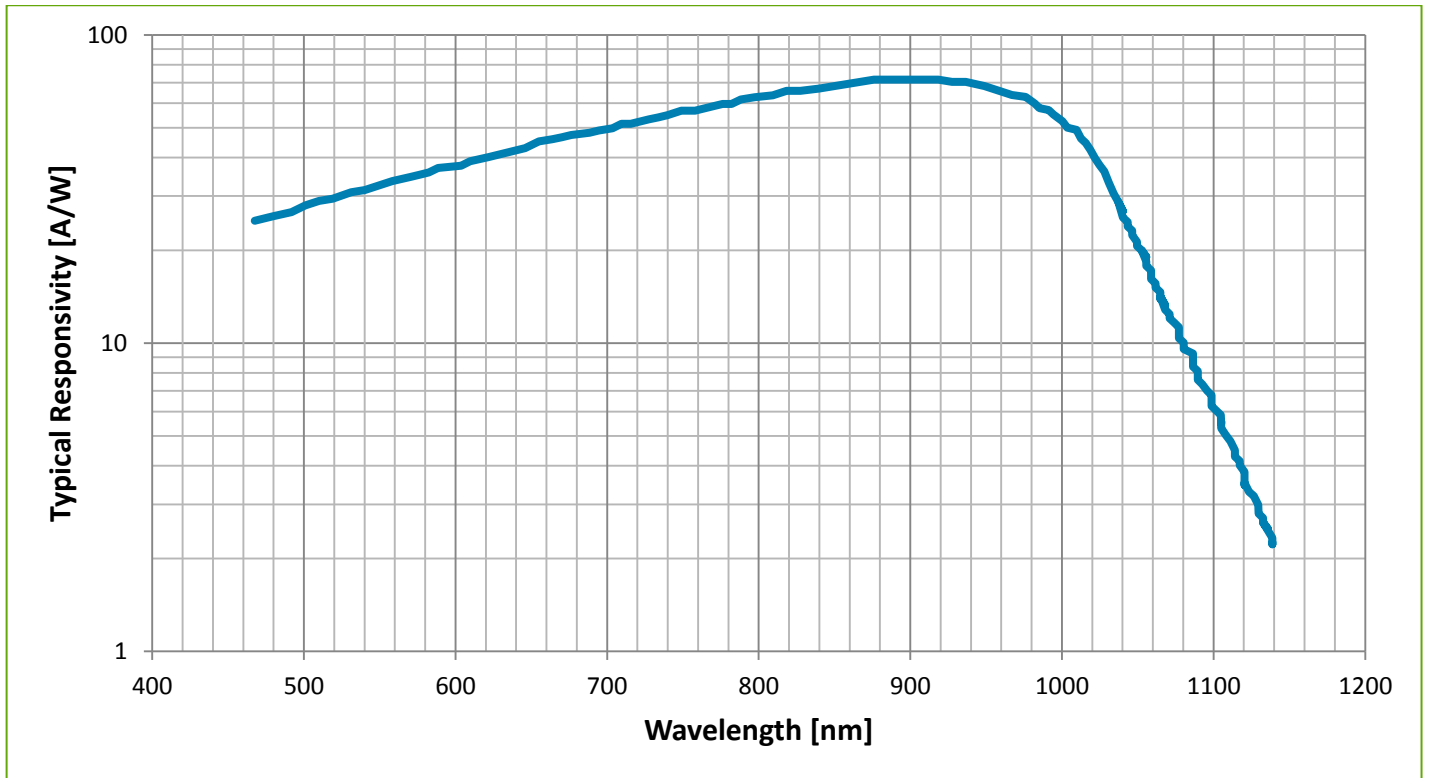

Photodiode C30817EH series
 Silicon Avalanche Photodiode for General-Purpose Applications

Figure 2 – Typical Responsivity at 900 nm as a function of Operating Voltage, V_{op}

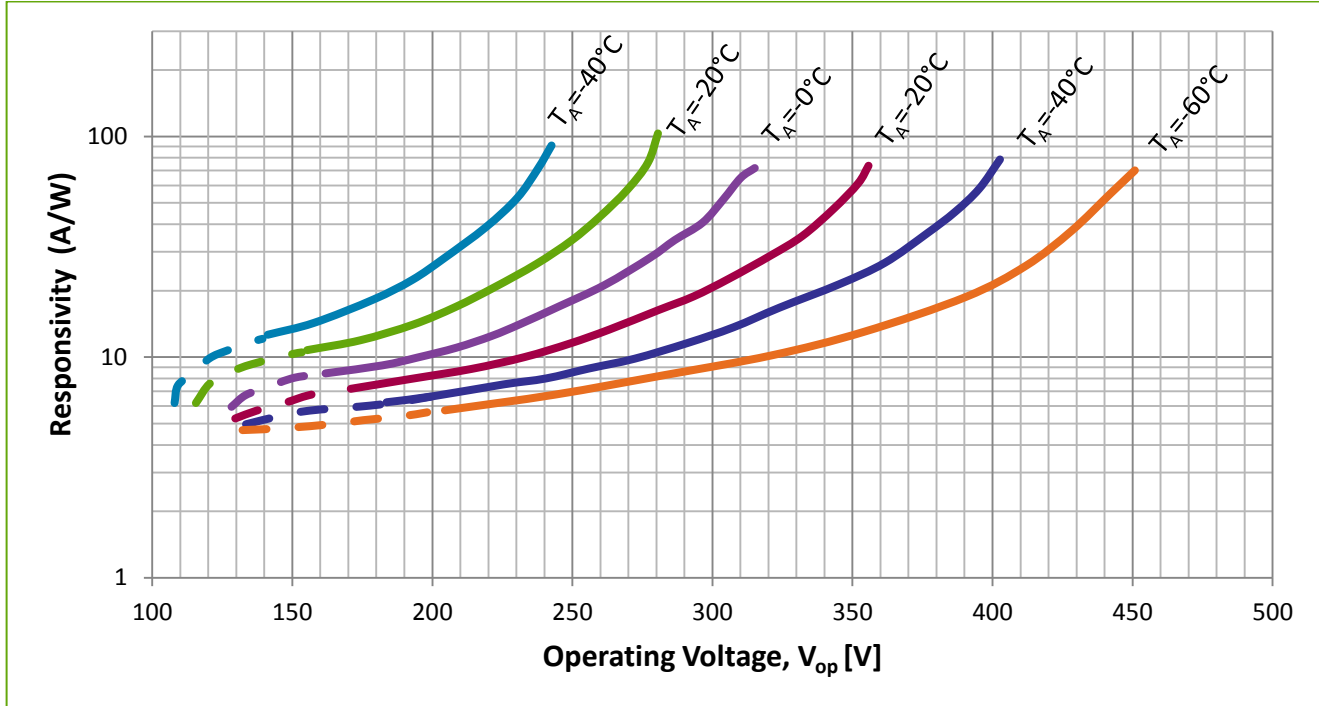
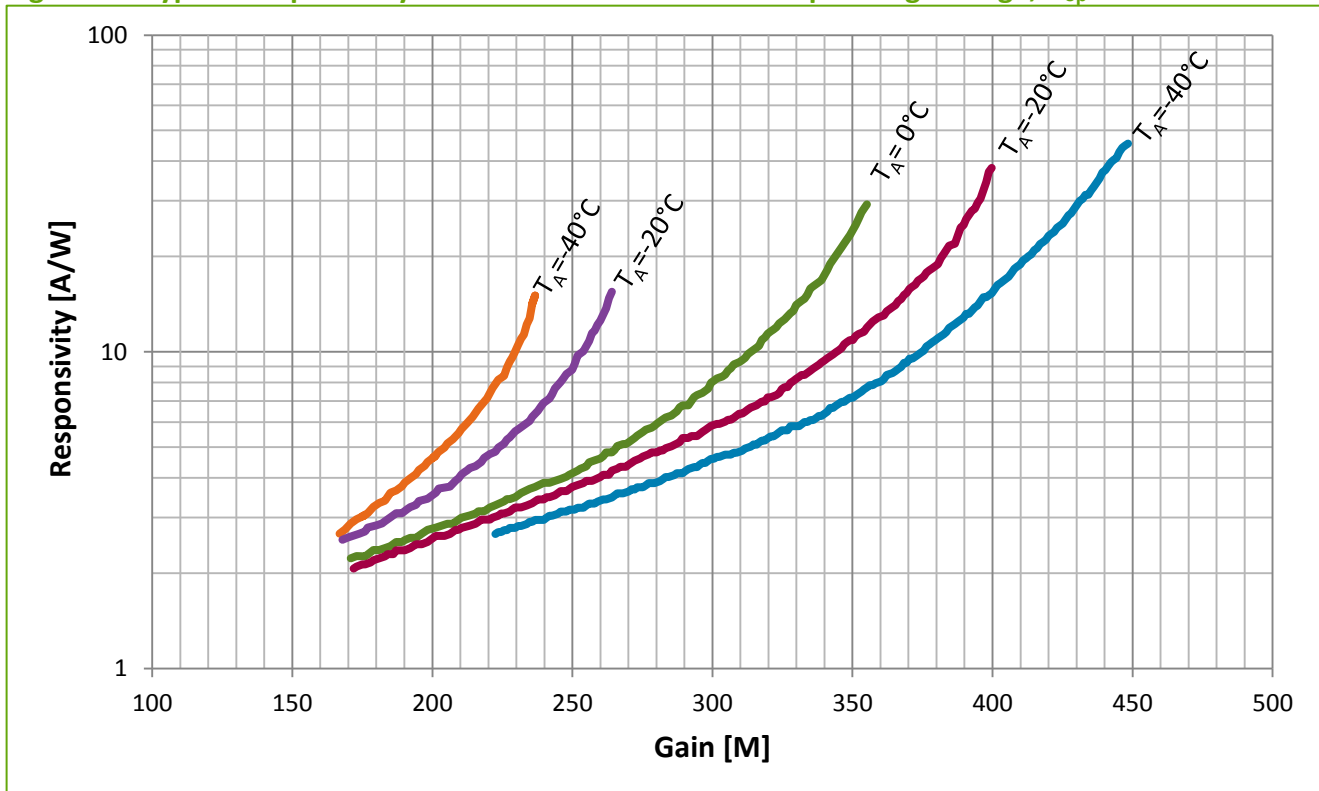

Figure 3 – Typical Responsivity at 1060 nm as a function of Operating Voltage, V_{op}



Photodiode C30817EH series
Silicon Avalanche Photodiode for General-Purpose Applications

Figure 4 – Typical Dark Current as a function of Operating Voltage, V_{op}
Test conditions: Case temperature = 22°C

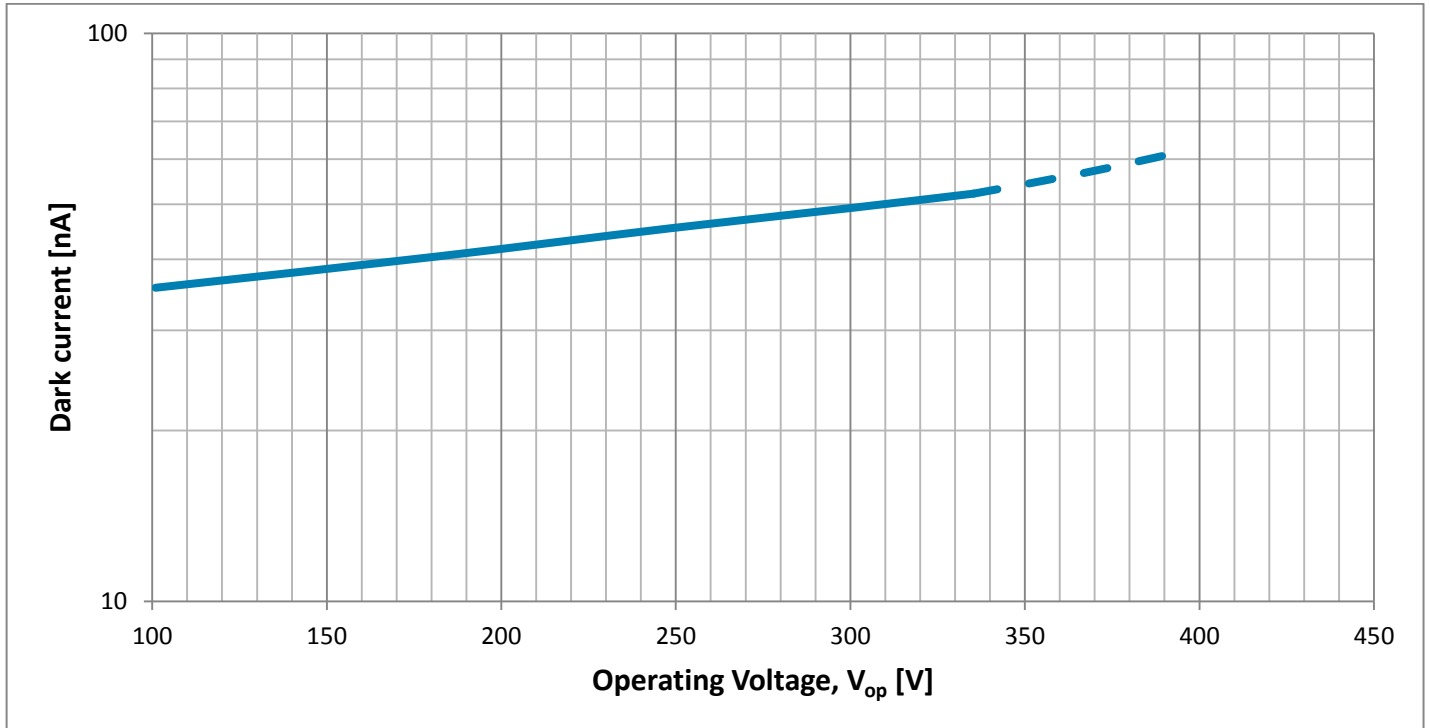
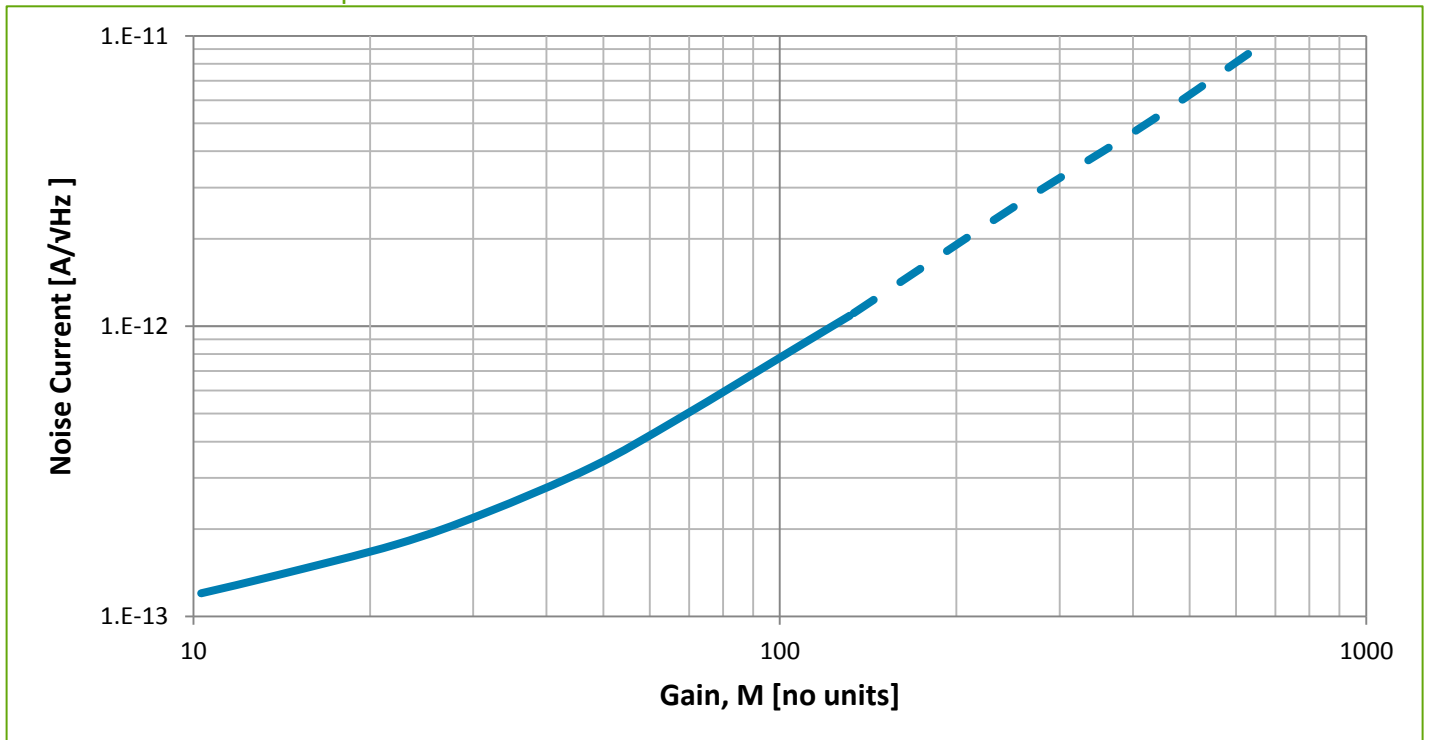

Figure 5 – Typical Noise Current as a function of Gain
Test conditions: Case temperature = 22°C



Photodiode C30817EH series
Silicon Avalanche Photodiode for General-Purpose Applications

Figure 6 – Typical Gain as a function of Light Spot Position

Test conditions: Case temperature = 22°C, Detector center = 0, Spot diameter= 0.0254 mm

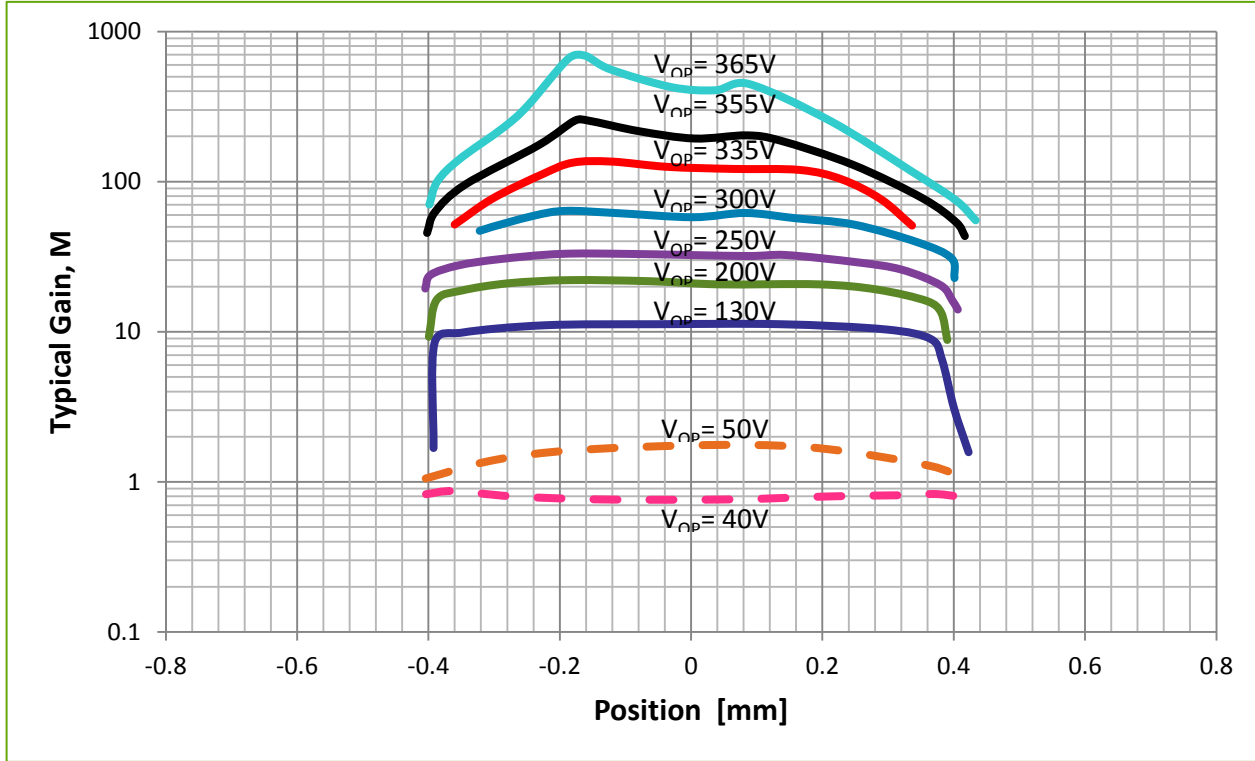
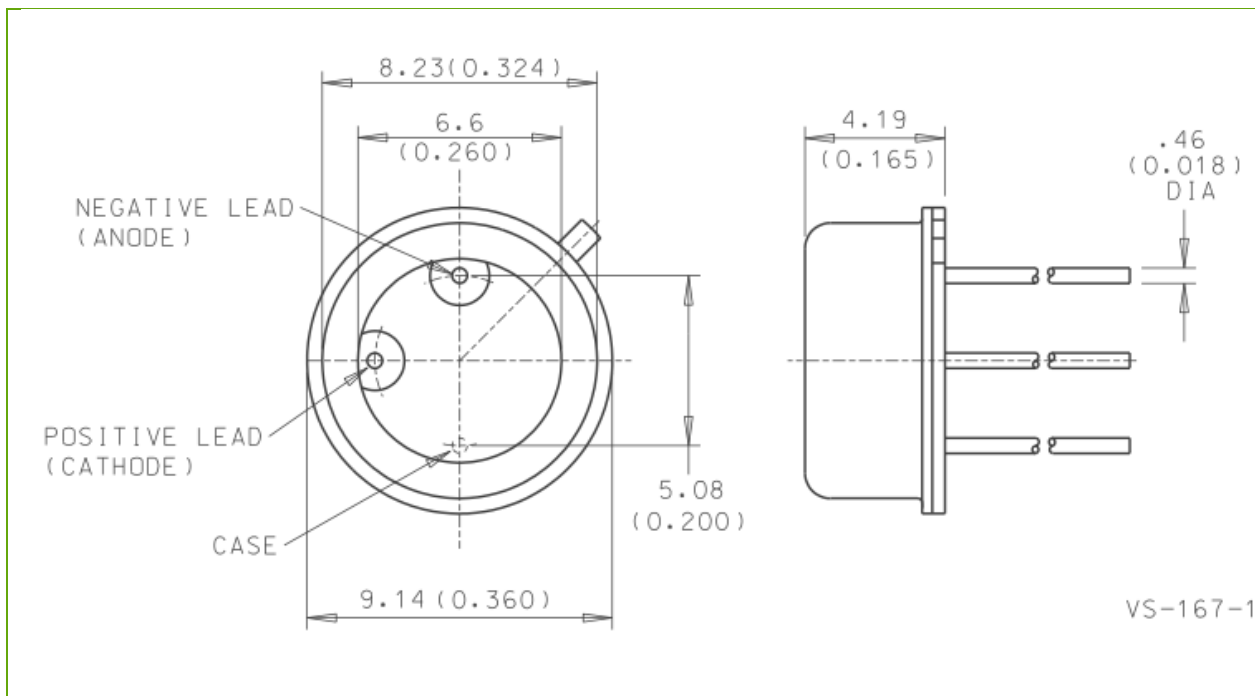

Figure 7 – Mechanical Characteristic – C30817EH – reference dimensions shown in mm (inches)



Photodiode C30817EH series

Silicon Avalanche Photodiode for General-Purpose Applications

Figure 9 – Approximate field of view

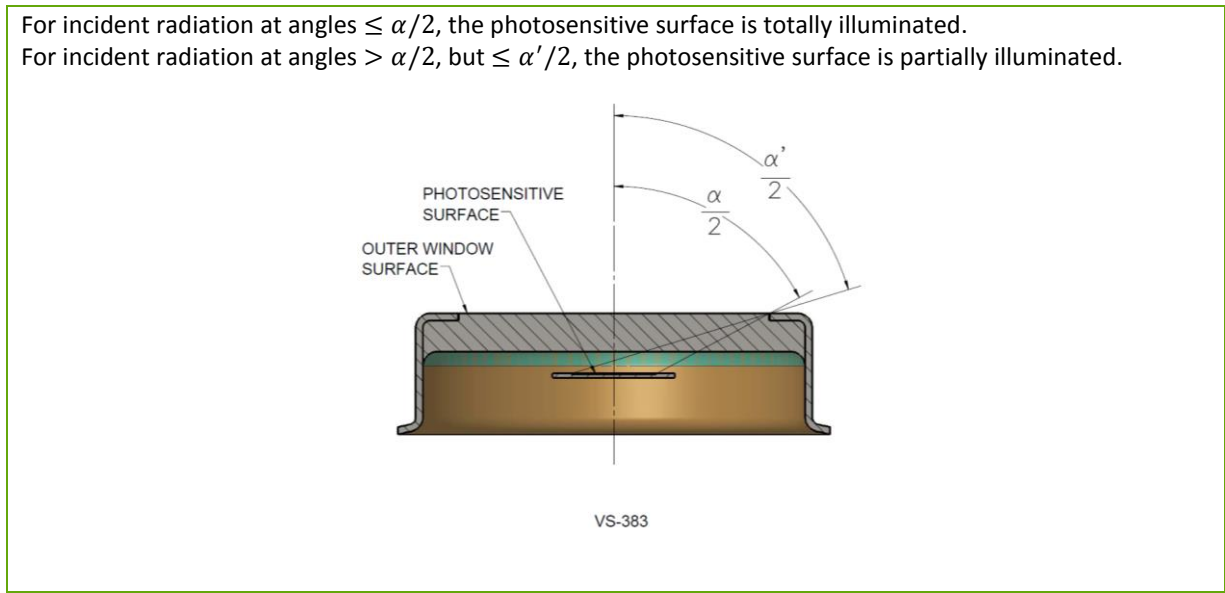

RoHS Compliance

The C30817EH is designed and built to be fully compliant with the European Union Directive 2011/65/EU – Restriction of the use of certain Hazardous Substances (RoHS) in Electrical and Electronic equipment.



Warranty

A standard 12-month warranty following shipment applies. Any warranty is null and void if the photodiode window has been opened.

About Excelitas Technologies

Excelitas Technologies is a global technology leader focused on delivering innovative, customized solutions to meet the lighting, detection and other high-performance technology needs of OEM customers.

Excelitas has a long and rich history of serving our OEM customer base with optoelectronic sensors and modules for more than 45 years beginning with PerkinElmer, EG&G, and RCA. The constant throughout has been our innovation and commitment to delivering the highest quality solutions to our customers worldwide.

From analytical instrumentation to clinical diagnostics, medical, industrial, safety and security, and aerospace and defense applications, Excelitas Technologies is committed to enabling our customers' success in their specialty end-markets. Excelitas Technologies has approximately 5,000 employees in North America, Europe and Asia, serving customers across the world.

Excelitas Technologies
22001 Dumberry Road
Vaudreuil-Dorion, Quebec
Canada J7V 8P7
Telephone: (+1) 450 424 3300
Toll-free: (+1) 800 775 6786
Fax: (+1) 450 424 3345
detection@excelitas.com

Excelitas Technologies
GmbH & Co. KG
Wenzel-Jaksch-Str. 31
D-65199 Wiesbaden
Germany
Telephone: (+49) 611 492 430
Fax: (+49) 611 492 165
detection.europe@excelitas.com

Excelitas Technologies Singapore, Pte. Ltd.
8 Tractor Road
Singapore 627969
Telephone: (+65) 6775 2022 (Main number)
Telephone: (+65) 6770 4366 (Customer Service)
Fax: (+65) 6778-1752
detection.asia@excelitas.com



For a complete listing of our global offices, visit www.excelitas.com/locations

© 2016 Excelitas Technologies Corp. All rights reserved. The Excelitas logo and design are registered trademarks of Excelitas Technologies Corp. All other trademarks not owned by Excelitas Technologies or its subsidiaries that are depicted herein are the property of their respective owners. Excelitas reserves the right to change this document at any time without notice and disclaims liability for editorial, pictorial or typographical errors.