

## C30927EH-01, -02 and -03

### Quadrant Silicon Avalanche Photodiode for Tracking Applications



#### Key Features

- Full Angle for Totally illuminated Photosensitive Surface greater than 90 degrees
- High Quantum Efficiency -  
C30927EH-03 85% typically at 800 nm  
C30927EH-02 85% typically at 900 nm  
C30927EH-01 18% typically at 1060nm
- Fast Time Response -  
Rise Time typically 3 ns  
Fall Time Typically 3 ns
- Large Area : 1.77mm<sup>2</sup>
- Hermetically Sealed Low Profile TO-8 Packages

#### Applications

- Tracking
- Alignment
- “Friend or Foe” identification

The C30927EH-01, C30927EH-02 and C30927EH-03 types are quadrant silicon photodiodes made using a double diffused “reach-through” structure. The quadrant structure has a common avalanche junction, with separation of the quadrants achieved by segmentation of the light-entry p+ surface opposite the junction. With this design, there is no dead space between the elements and therefore no loss of response at boresight.

They are optimized for use at wavelengths of 1060, 900 and 800 nm respectively. Each device type will provide high responsivity and excellent performance when operated within about 50 nm of the specified wavelength.

The quadrant avalanche photodiodes are useful in a variety of tracking and alignment applications.

**Table 1 – Mechanical and Optical Characteristics**

Parameter	Symbol		Unit
Shape		Circular	
Configuration		Quadrant	
Photosensitive Surface:			
Useful area	A	1.77	mm <sup>2</sup>
Useful diameter	d	1.55	mm

## Quadrant Silicon Avalanche Photodiode for Tracking Applications

**Table 2 – Electro-Optical Characteristics**

Case Temperature  $T_A = 22\text{ }^\circ\text{C}$ ; at the DC reverse operating voltage,  $V_{op}$ , and light spot diameter of 1.0 mm (0.04 inches) centered at boresight, unless otherwise specified<sup>1</sup>.

Parameter	Symbol	Minimum	Typical	Maximum	Units
Breakdown Voltage	$V_{br}$	350	425	485	V
Temperature Coefficient of $V_{op}$ for Constant M	$V_{op}$		2.4		V/ $^\circ\text{C}$
Gain	M		100		
Responsivity at 800 nm at 900 nm at 1060 nm	R	45 50 12	55 62 15		A/W
Quantum Efficiency at 800 nm at 900 nm at 1060 nm	Q.E.		85 85 18		%
Total Dark Current	$I_d$		100	200	nA
Noise Current ( $f=10\text{kHz}$ , $\Delta f=1.0\text{Hz}$ , See Figure 5)	$i_n$		1.0	1.5	pA/ $\sqrt{\text{Hz}}$
Capacitance total all quadrants between quadrants	$C_d$		3	5 0.5	pF
Resistance Between Paralleled Quadrant Pairs (See Figure 6)		8		50	k $\Omega$
Crossover at Boresight (25 $\mu\text{m}$ spot, 10% to 90%, See Figure 8)			75		$\mu\text{m}$
Series Resistance	$R_s$			15	$\Omega$
Rise/Fall Time, $R_L = 50\Omega$ , $\lambda=900\text{nm}$ : 10% to 90% points 90% to 10% points	$t_r$ $t_f$		3 3	4 4	ns

<sup>1</sup> A specific value of  $V_{op}$  is supplied with each device when the photodiode is operated at this voltage, the device will meet the electrical characteristics limits shown above, the voltage value will be within the range of 275 to 425 volts.

## Quadrant Silicon Avalanche Photodiode for Tracking Applications

**Table 3 – Absolute – Maximum Ratings, Limiting Values**

Parameter	Symbol	Minimum	Maximum	Unit	Remarks/Conditions
Reverse Bias Current			200	$\mu\text{A}$	
Photocurrent Density : average value peak value	$J_p$		5 20	$\text{mA}/\text{mm}^2$	Continuous operation
Forward Current: average value peak value	$I_F$		5 50	mA	Continuous operation (For 1 second duration, non-repetitive)
Maximum total power Dissipation			0.1	W	At 22 °C
Storage Temperature	$T_{\text{stg}}$	-60	100	°C	
Operating Temperature	$T_o$	-40	60	°C	
Soldering			200	°C	5 seconds, leads only

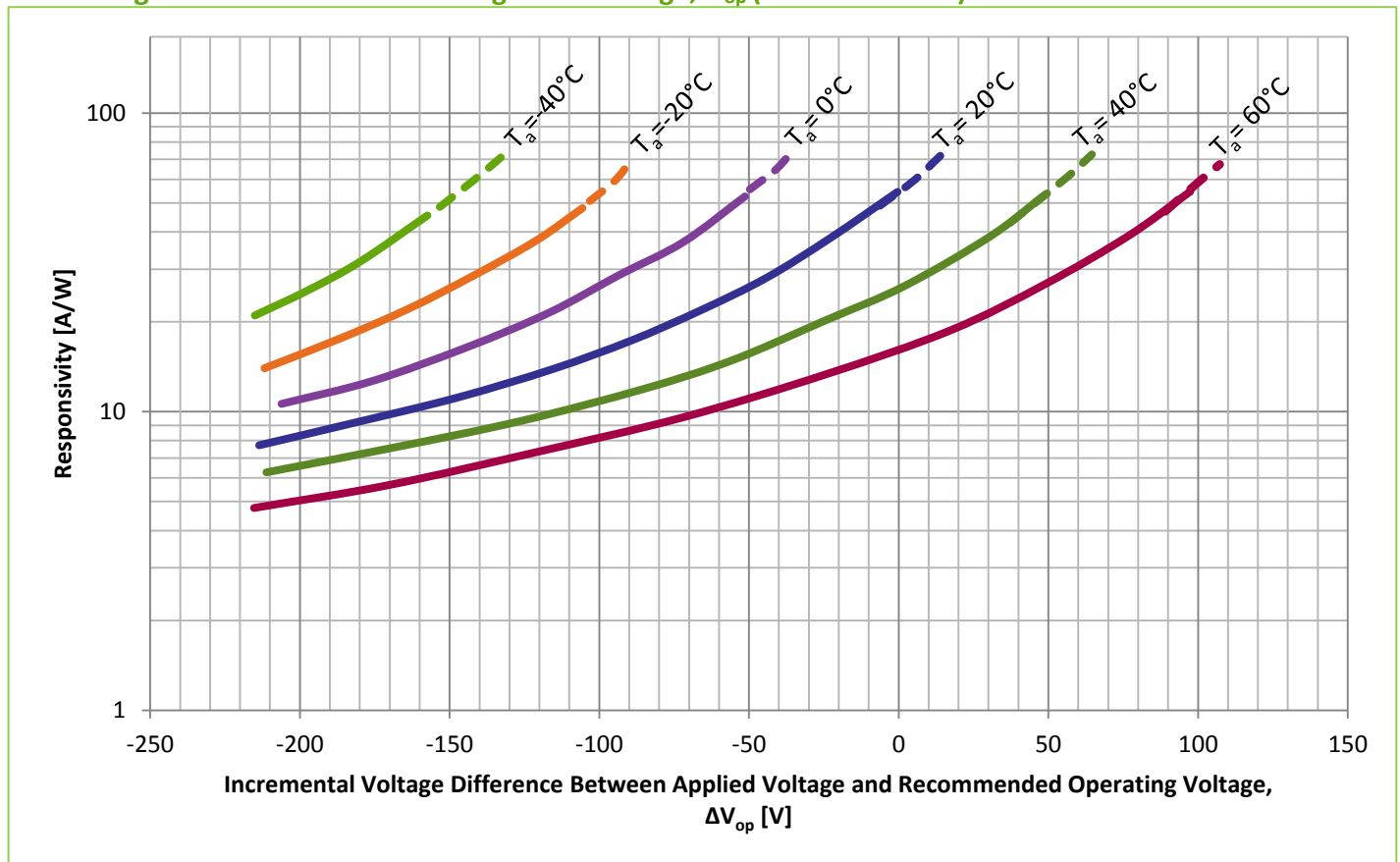
**Figure 1 – Typical Variation of Responsivity at 800 nm for type C30927E-03 as a function of Temperature and Voltage Difference from the Designated Voltage,  $V_{op}$  (See Footnote 1)**

## Quadrant Silicon Avalanche Photodiode for Tracking Applications

Figure 2 – Typical Variation of Responsivity at 900 nm for type C30927E-02 as a function of Temperature and Voltage Difference from the Designated Voltage,  $V_{op}$  (See Footnote 1)

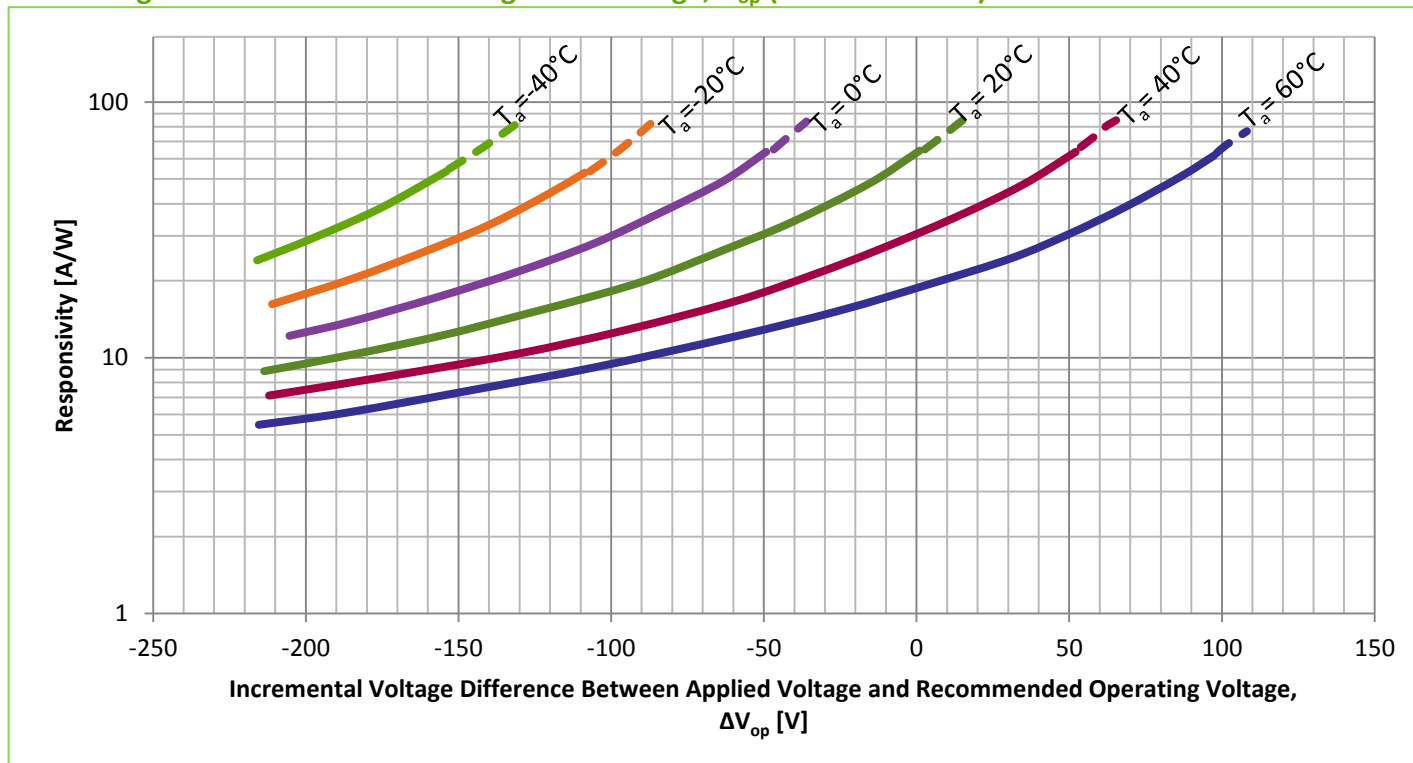
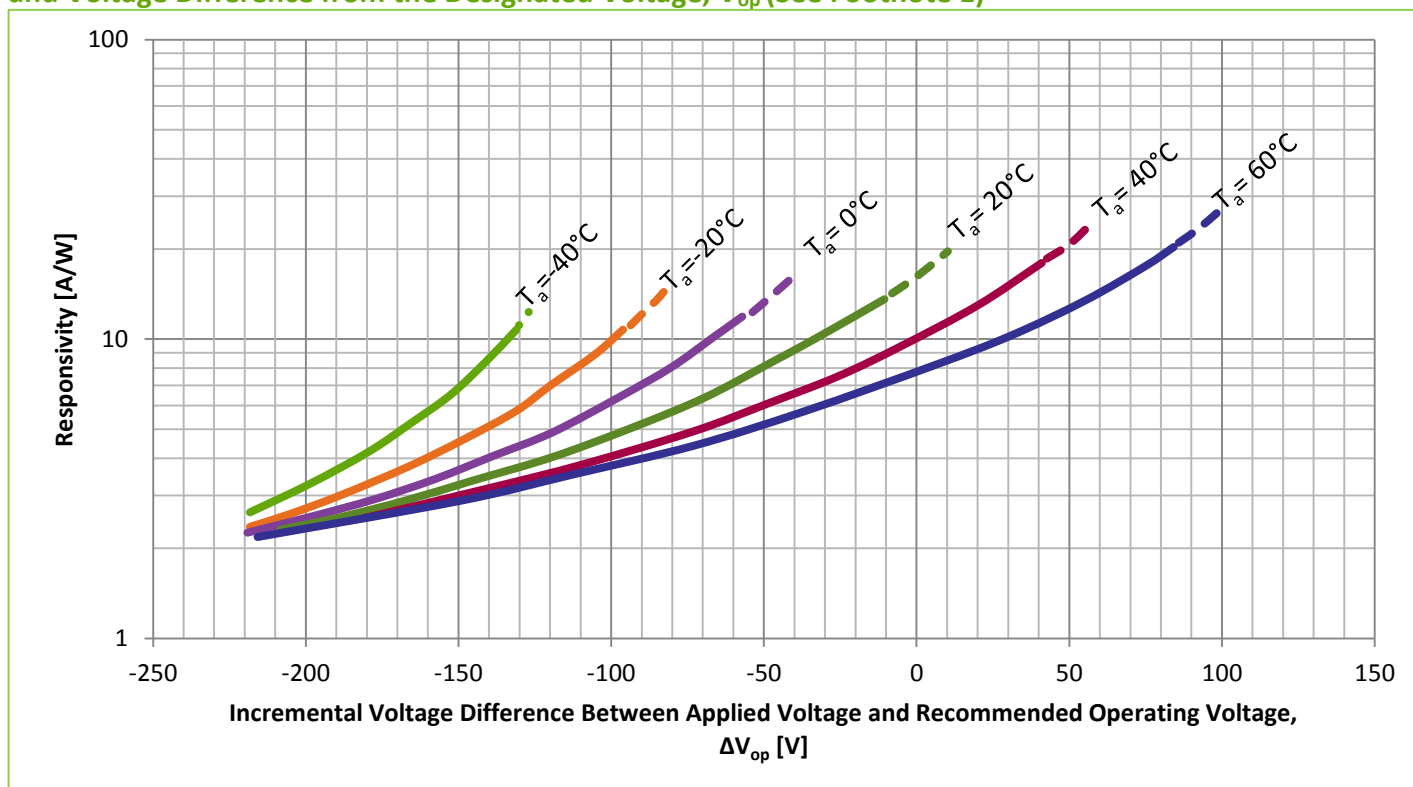

Figure 3 – Typical Variation of Responsivity at 1060 nm for type C30927E-01 as a function of Temperature and Voltage Difference from the Designated Voltage,  $V_{op}$  (See Footnote 1)



## Quadrant Silicon Avalanche Photodiode for Tracking Applications

Figure 4 – Typical Total Dark Current as a function of Operating Voltage,  $V_{op}$

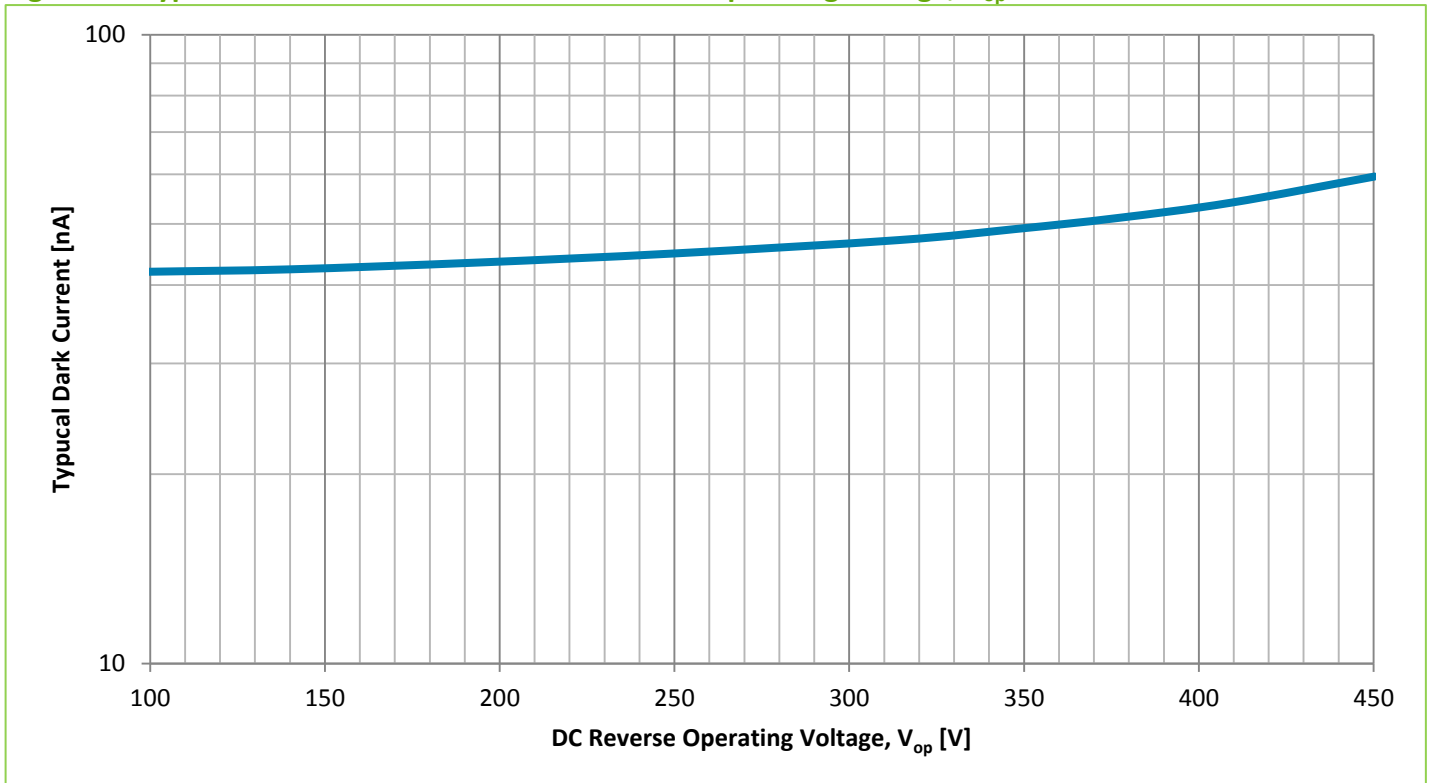
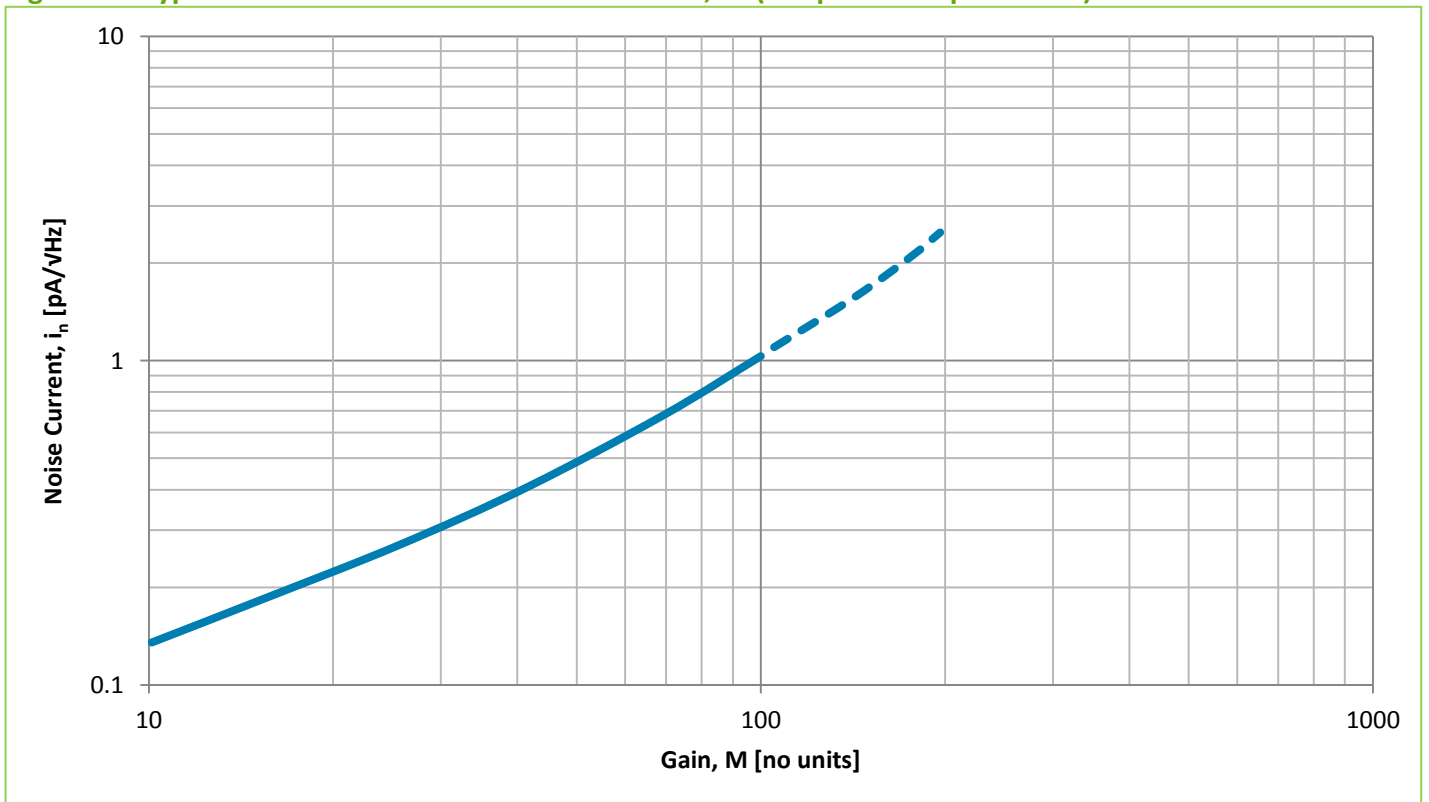

Figure 5 – Typical Noise Current as a function of Gain, M (All quadrants paralleled)



## Quadrant Silicon Avalanche Photodiode for Tracking Applications

Figure 6 – Typical Inter-electrode Resistance as a function of Voltage Difference from the Designated Voltage,  $V_{op}^2$

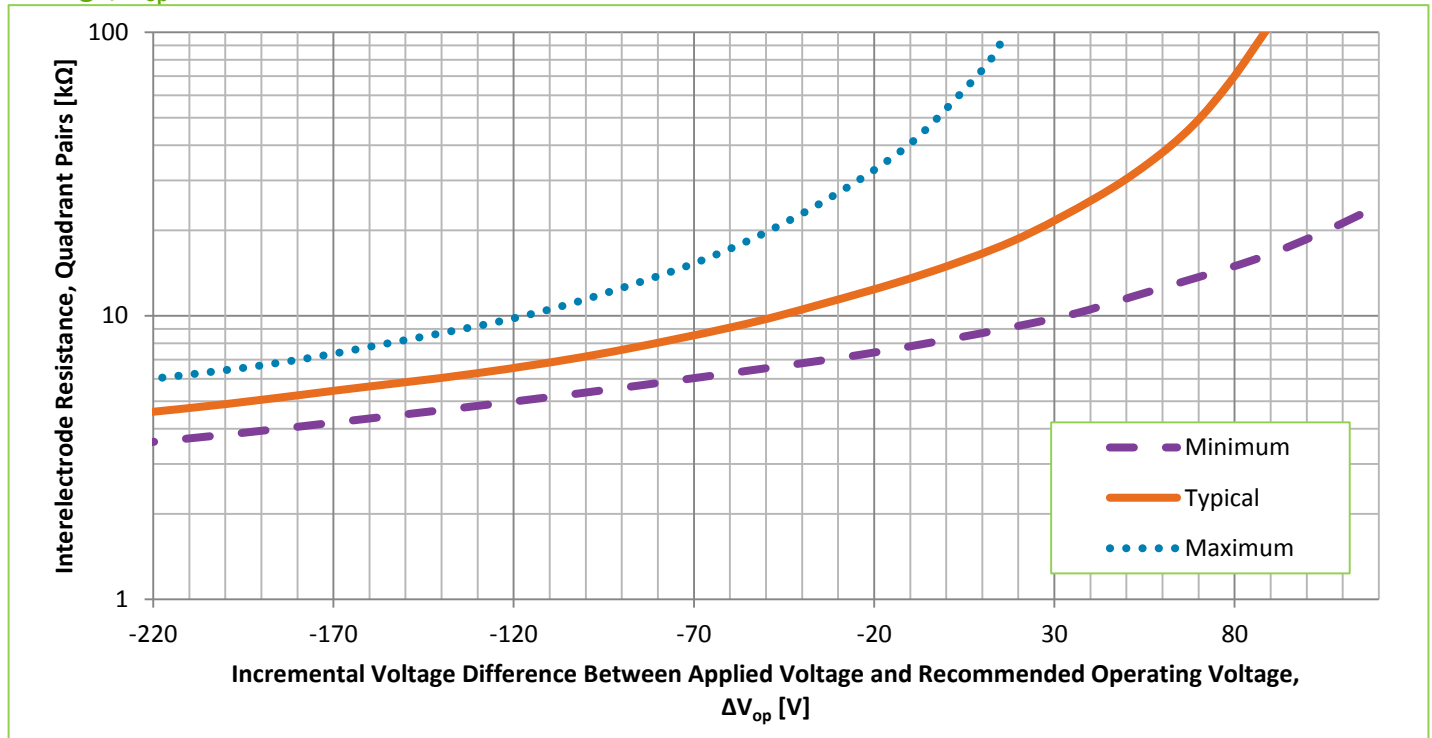
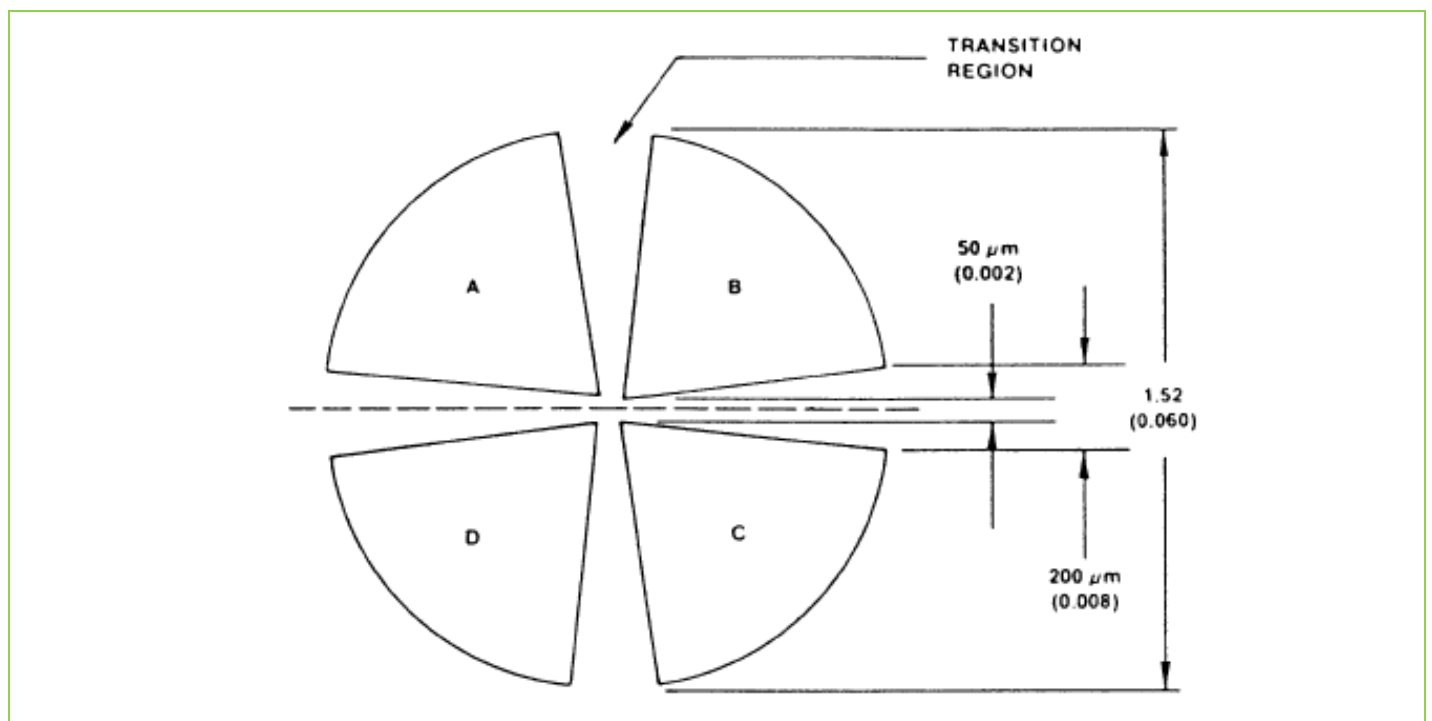

Figure 7 – Quadrant Geometry



<sup>2</sup> There is a resistance between the quadrant elements which varies as a function of the applied voltage. In Figure 6, the typical measured resistance between paralleled quadrant pairs is shown. For equivalent circuit considerations, the resistive element between any two adjacent quadrants is twice this value.

## Quadrant Silicon Avalanche Photodiode for Tracking Applications

**Figure 8 – Scan Showing Typical Crossover Characteristic at Boresight, Quadrant B & C Grounded**  
 Dotted line from Figure 7 represents scan line, Spot size = 25 μm

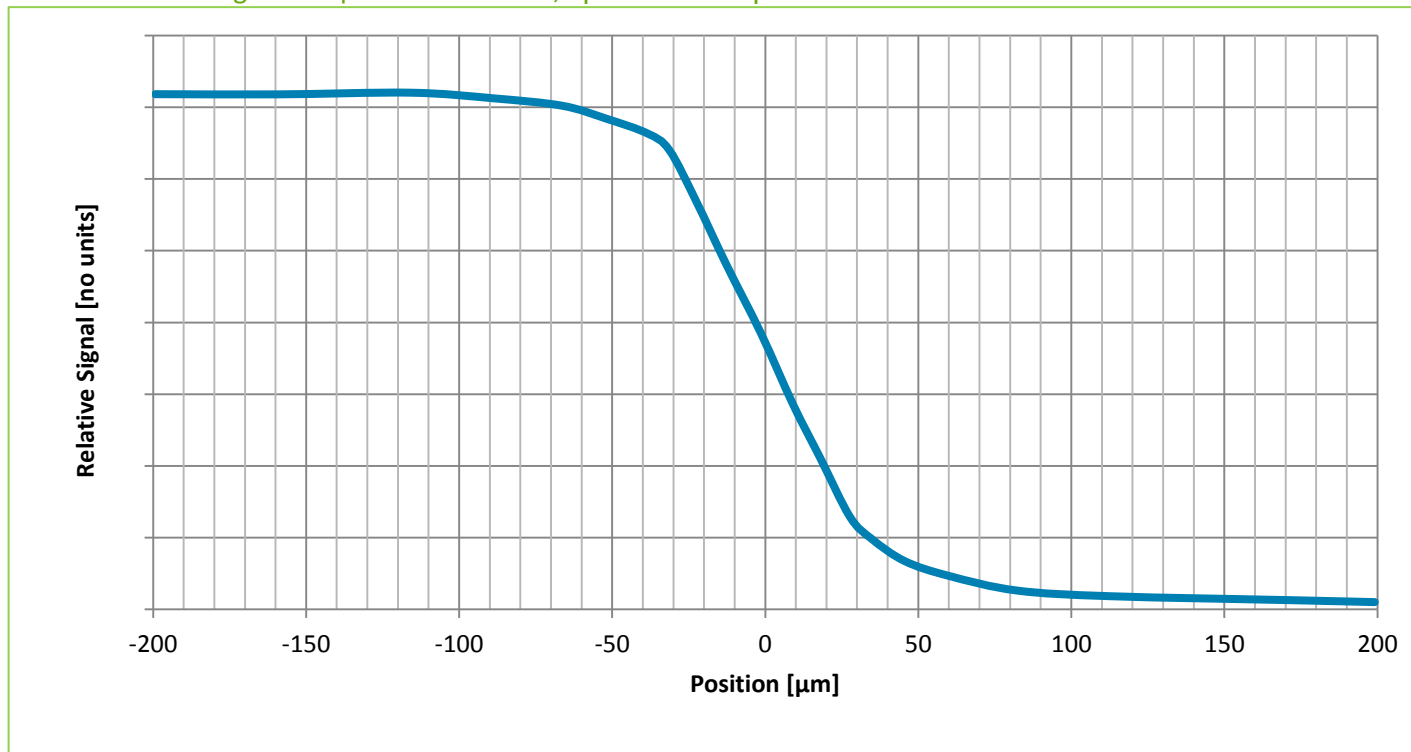

**Figure 9 – Typical Response as a function of Light Spot Position Scanned Diagonally Through Boresight – All Quadrants Connected<sup>3</sup>.**

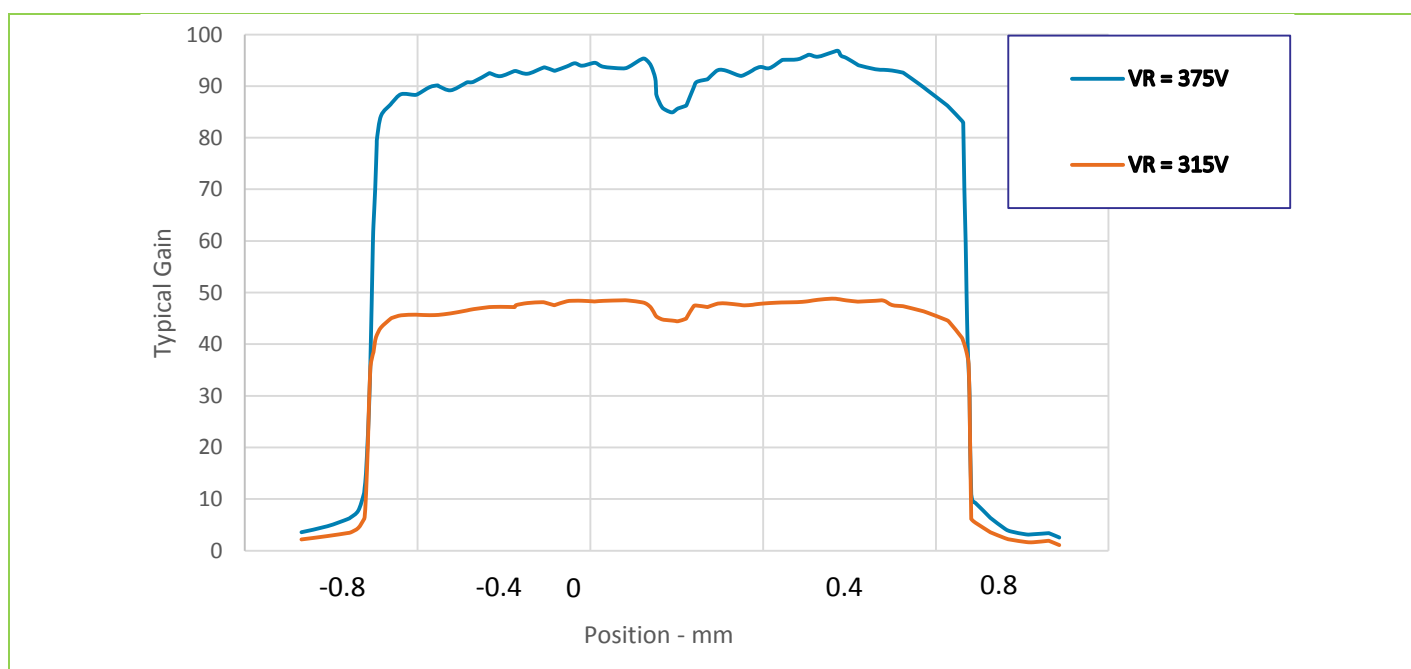

<sup>3</sup> The response dips at boresight (approx.. 10%) observed in the scans of Figure 9 are caused by a slight difference in antireflection coating in the crosshair region as compared to the rest of the active area.

## Quadrant Silicon Avalanche Photodiode for Tracking Applications

Figure 10 – Dimensional Outline and Pin Connections

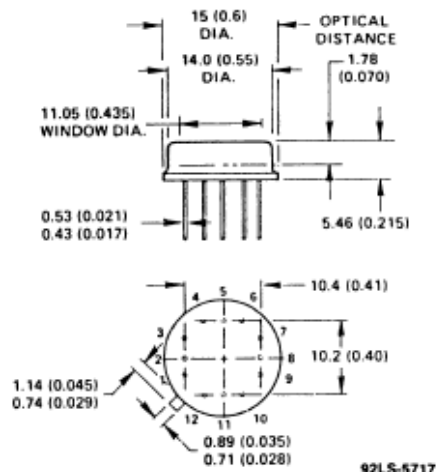

### Pin Connections

1. Quadrant C, Anode
2. No Connection, Do Not Use
3. Quadrant B, Anode
4. No Connection, Do Not Use
5. Case (Ground)
6. No Connection, Do Not Use
7. Quadrant A, Anode
8. No Connection, Do Not Use
9. Quadrant D, Anode
10. No Connection, Do Not Use
11. Positive Lead (Cathode)
12. No Connection, Do Not Use

Optical distance from outside surface of window to quadrant avalanche photodiode surface = 1.78 mm (0.070 inch).

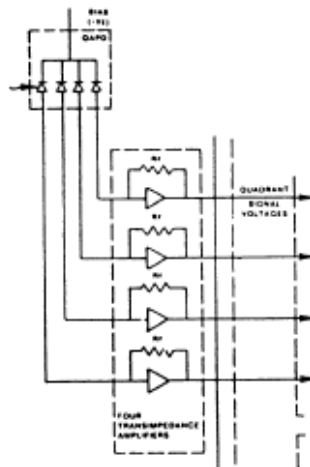

C30927EH

## Quadrant Silicon Avalanche Photodiode for Tracking Applications

### RoHS Compliance

The C30927EH Quadrant Silicon Avalanche photodiode series is designed and built to be fully compliant with the European Union Directive 2011/65/EU – Restriction of the use of certain Hazardous Substances (RoHS) in Electrical and Electronic equipment.



### Warranty

A standard 12-month warranty following shipment applies. Any warranty is null and void if the photodiode window has been opened.

### About Excelitas Technologies

Excelitas Technologies is a global technology leader focused on delivering innovative, customized solutions to meet the lighting, detection and other high-performance technology needs of OEM customers.

Excelitas has a long and rich history of serving our OEM customer base with optoelectronic sensors and modules for more than 45 years beginning with PerkinElmer, EG&G, and RCA. The constant throughout has been our innovation and commitment to delivering the highest quality solutions to our customers worldwide.

From analytical instrumentation to clinical diagnostics, medical, industrial, safety and security, and aerospace and defense applications, Excelitas Technologies is committed to enabling our customers' success in their specialty end-markets. Excelitas Technologies has approximately 3,000 employees in North America, Europe and Asia, serving customers across the world.

**Excelitas Technologies**  
22001 Dumberry Road  
Vaudreuil-Dorion, Quebec  
Canada J7V 8P7  
Telephone: (+1) 450 424 3300  
Toll-free: (+1) 800 775 6786  
Fax: (+1) 450 424 3345  
[detection@excelitas.com](mailto:detection@excelitas.com)

**Excelitas Technologies  
GmbH & Co. KG**  
Wenzel-Jaksch-Str. 31  
D-65199 Wiesbaden  
Germany  
Telephone: (+49) 611 492 430  
Fax: (+49) 611 492 165  
[detection.europe@excelitas.com](mailto:detection.europe@excelitas.com)

**Excelitas Technologies Singapore, Pte. Ltd.**  
8 Tractor Road  
Singapore 627969  
Telephone: (+65) 6775 2022 (Main number)  
Telephone: (+65) 6770 4366 (Customer Service)  
Fax: (+65) 6778-1752  
[detection.asia@excelitas.com](mailto:detection.asia@excelitas.com)

**EXCELITAS®**  
TECHNOLOGIES

For a complete listing of our global offices, visit [www.excelitas.com/locations](http://www.excelitas.com/locations)

© 2012 Excelitas Technologies Corp. All rights reserved. The Excelitas logo and design are registered trademarks of Excelitas Technologies Corp. All other trademarks not owned by Excelitas Technologies or its subsidiaries that are depicted herein are the property of their respective owners. Excelitas reserves the right to change this document at any time without notice and disclaims liability for editorial, pictorial or typographical errors.