

Mamba

EXCELITAS
TECHNOLOGIES®

Light weight Optics for Night Vision Goggles

Mamba offers high performance in a lightweight form. The Objective and Eyepiece are designed together to extract all the performance from high end II tubes. The optics are an outstanding choice for tactical professionals and first responders. Mamba provides a crisp f/1.2 and excellent FOV that aids situational awareness and allows the operator to effectively use in a monocular or binocular low-light environment. The viewing angle combined with bright optics makes the optics suited for aviation, close-quarter engagement, surveillance and recon. The lightweight optic is configurable to customer needs.



F/1.2

26mm
EFL

TUBE

ALL GENS



**18mm
TUBE**

White &
Green
Phosphor

COTS



**ITAR
FREE**



Applications

- Border Surveillance
- Law Enforcement
- Marine and Naval Surveillance

Enabling the future through light

www.excelitas.com

Mamba

Light weight Optics for Night Vision Goggles

Mamba40 Objective Parameters

Resolution:	72 lp/mm
Distortion:	Less than 6%
Effective Focal Length:	26mm
	F# 1.2
Field of View:	40°
Tube Compatibility:	Latest Generation of High Resolution Tubes
Sensor:	18mm I2 tube
Spectral Range:	600nm to 900nm
Transmission:	92%
Weight:	35g

Mamba40 Eyepiece Parameters

Resolution:	72 lp/mm
Distortion:	Less than 6%
Effective Focal Length:	26mm
Field of View:	40°
Tube Compatibility:	Latest Generation of High Resolution Tubes
Sensor:	18mm I2 tube
Spectral Range:	420nm to 620nm
Transmission:	85%
Weight:	25g

Environmental Specifications

Operating Temperature:	-40°C to + 55°C
Storage Temperature:	-51°C to +71°C
Vibration:	5 to 55Hz and force up to 2.5g
Mechanical Shock:	40g / 6ms
Sealing:	IP68

Mechanical Interface

Size

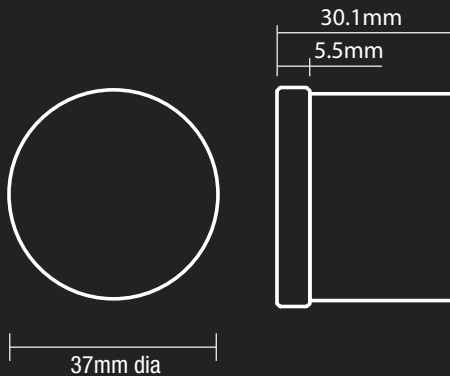
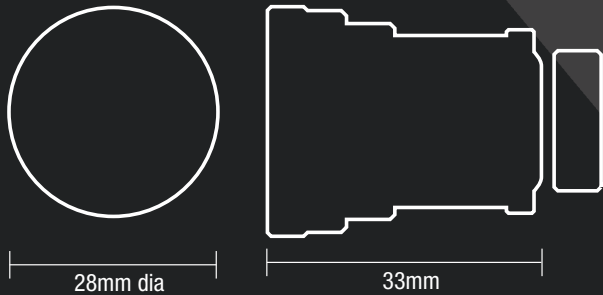

Parts are subject to controls under the Singapore, Strategic Goods (Control) Act (SGCA).

Excelitas Singapore is registered and compliant, with Singapore Customs and adheres to the Strategic Goods (Control) Act (SGCA), a set of government regulations that controls the manufacturing and exporting activities of defence articles.

For technical information contact:

Excelitas Singapore Pte Ltd
8 Tractor Road, Singapore, 627969

email: AO.Nightvision@excelitas.com

