

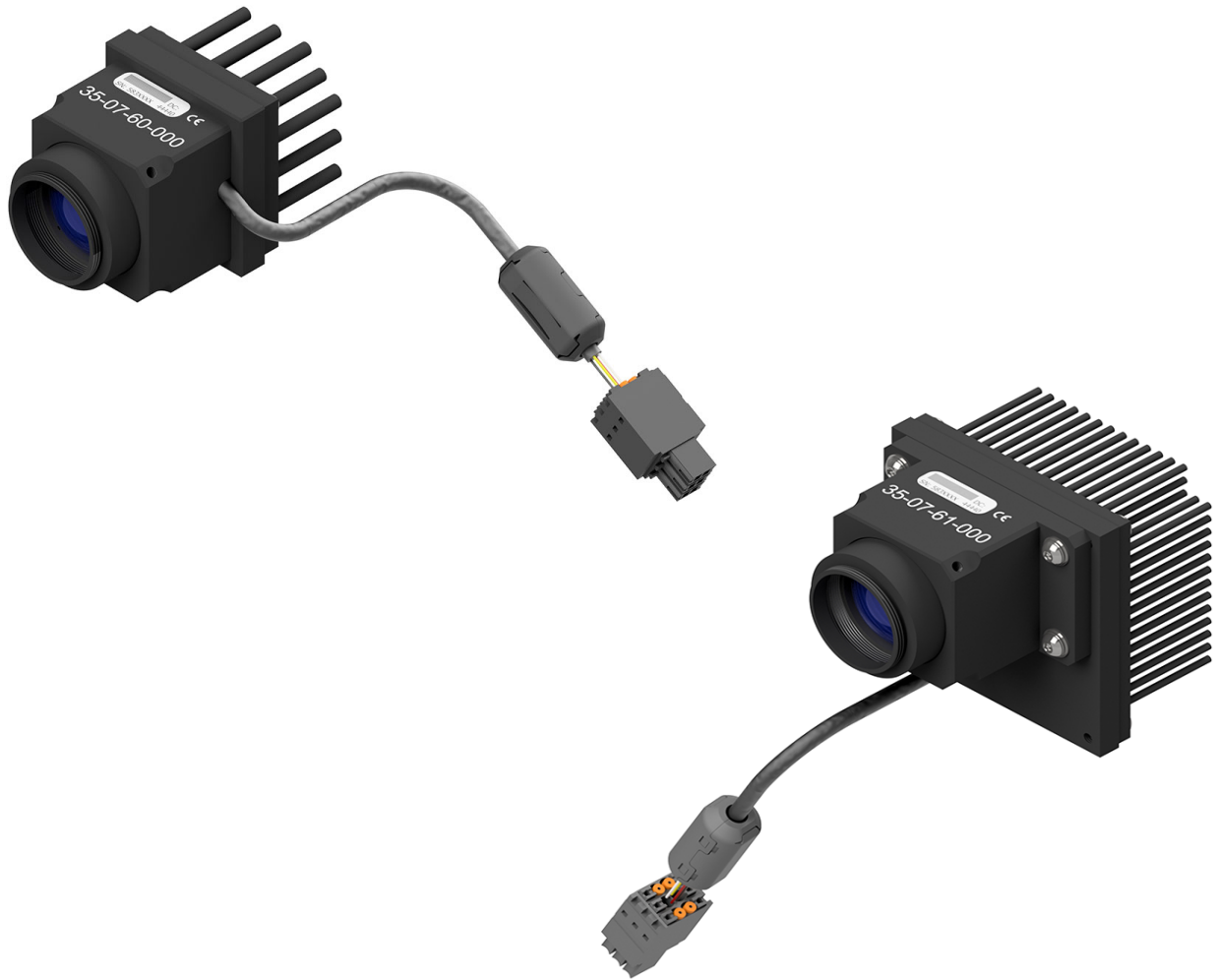

# FUSION 1.5 A and 3 A Illuminator User Manual



Part No: MAN-350011B



Part No: MAN-350011B

Status: Released

**Excelitas Technologies Corp.**

2545 Railroad Street, Suite 300

Pittsburgh, PA 15222

United States

[www.excelitas.com](http://www.excelitas.com)

Phone Europe

+49 (0) 551 6935-0

Phone North America

+1 (800) 429 0257

Phone Asia/Pacific

+65 64 99 7777

Technical support: [Inspection@excelitas.com](mailto:Inspection@excelitas.com)

© 2025 Excelitas Technologies Corp. All rights reserved. Excelitas® and Optem® are registered trademarks of the Excelitas group of companies. All other products and services are either trademarks or registered trademarks of their respective owners. Excelitas reserves the right to change this document at any time without notice and disclaims liability for editorial, pictorial or typographical errors. This document may not be reproduced or transmitted, in whole or in part, in any form or by any means, electronic or mechanical, for any purpose without written permission from Excelitas.

# Contents

## Preface

Document Conventions .....	9
List of Acronyms .....	10
Safety .....	10
Warning Labels .....	10
Safety Precautions.....	11
General Precautions .....	11
ESD Precautions .....	11

## 1 Introduction

Optem® FUSION Illuminators Overview .....	14
Intended Use .....	14
Regulatory Compliance .....	14
Changes to Excelitas Products .....	15
Technical Support .....	15
Limited Warranty Information .....	15
Warranty Repair Process.....	16

## 2 General Description

Main Components .....	18
Illuminator Cable .....	19
Adjusting Optics.....	20
Adjusting Optics to Provide Kohler illumination .....	20
Adjusting Optics for Lower Lenses to Obtain Best Illumination .....	22

## 3 Specifications and Dimensions

Mechanical Specifications .....	24
---------------------------------	----

Electrical Specifications ..... 26  
    Electrical Characteristics ..... 26  
Optical Specifications ..... 27  
Environmental Specifications ..... 28

# List of Figures

- Figure 1 Optem® FUSION Illuminators – 1.5 A ..... 18
- Figure 2 Optem® FUSION Illuminators – 3 A ..... 18
- Figure 3 Optem® FUSION Illuminators Connector Pin Out (1.5 A and 3 A) ..... 19
- Figure 4 Adjusting the Illuminator Assembly Optics..... 21
- Figure 5 Optem® FUSION Illuminators – 1.5 A Unit Dimensions ..... 24
- Figure 6 Optem® FUSION Illuminators – 3 A Unit Dimensions ..... 25
- Figure 7 Typical Spectrum ..... 27

# List of Tables

Table 1 Document Conventions ..... 9

Table 2 1.5A LED Driver Connector Pin Assignments ..... 19

Table 3 3A LED Driver Connector Pin Assignments ..... 19

Table 4 LED Compartment Adjustment For Typical Optem® FUSION Objectives ..... 22

Table 5 Optem® FUSION Illuminators Electrical Characteristics ..... 26

Table 6 Luminous Flux Parameters ..... 27

# Revision History

Revision Date	Rev#	Issued By	Change Details
2023-09-26	A	Carmelo Scaffidi	First release.
2025-12-22	B	Carmelo Scaffidi	Second release. Update logo and branding information.

**THIS PAGE INTENTIONALLY LEFT BLANK**

# Preface

The following topics are covered:

- Document Conventions, pg. 9
- List of Acronyms, pg. 10
- Safety, pg. 10
  - Warning Labels, pg. 10
  - Safety Precautions, pg. 11

---

## Document Conventions

The following text conventions are used throughout this document.

**Table 1 Document Conventions**

Paragraph Format	Indicates
<b>NOTE:</b>	Useful information or helpful tips.
<b>CAUTION:</b>	Information about actions that could cause damage to the system or equipment. Identifies a potentially hazardous situation that could result in minor or moderate personal injury, damage to equipment, or loss of data.
<b>WARNING!</b>	Information that is essential to your safety. Identifies a potentially dangerous situation that could result in serious personal injury or death.
<b>Bold</b>	Noteworthy information.

---

## List of Acronyms

CE	Conformité Européenne
ESD	Electrostatic Discharge
LED	Light Emitting Diode
PWM	Pulse Width Modulation
RMA	Return Merchandise Authorization

---

## Safety

This section provides guidelines on the use and safety of the Optem® FUSION Illuminators, to avoid personal injury or damage to the illuminator.

## Warning Labels

Excelitas products have labels affixed to their packaging or enclosures, similar or identical to those shown below.

---

**WARNING!** *Be sure to read and follow all warning labels.*

---



Electrostatic discharge (ESD) can damage or destroy the product's electronic components. Observe precautions for handling these components (e.g., use anti-static mats, gloves, wrist straps).

## Safety Precautions

This section outlines the safety precautions that users must take when operating the Optem® FUSION Illuminators.

### General Precautions

Observe the following general safety precautions:

- Permit only authorized individuals to operate the Optem® FUSION Illuminators.
- Permit only authorized individuals to have access to controlled areas during Optem® FUSION Illuminators operation.
- The high power light emitted by the illuminator can cause eye damage.

### ESD Precautions

Handling of this product needs precautions against static electricity because this is a semiconductor product. Please take adequate measures to prevent any static electricity being produced such as the wearing of a wristband or anti-static gloves when handling this product.

Every manufacturing facility in regard to the product (plant, equipment, machine, carrier machine and conveyance unit) should be connected to ground and please avoid the product to be electric-charged.

**THIS PAGE INTENTIONALLY LEFT BLANK**

## CHAPTER

# 1

# Introduction

This chapter provides an overview of the Optem® FUSION 1.5A and 3A Illuminator, as well as some general product, warranty, and safety information.

The following topics are covered:

- [Optem® FUSION Illuminators Overview, pg. 14](#)
- [Intended Use, pg. 14](#)
  - [Regulatory Compliance, pg. 14](#)
- [Changes to Excelitas Products, pg. 15](#)
- [Technical Support, pg. 15](#)
- [Limited Warranty Information, pg. 15](#)
  - [Warranty Repair Process, pg. 16](#)

---

## Optem® FUSION Illuminators Overview

The Optem® FUSION Illuminators are high power LED illuminators designed for modern inspection and review applications. The illuminators should be used in conjunction with the Optem® FUSION Focus module and Optem® FUSION lower lenses or microscope objectives.

---

**WARNING!** *Do not look at the light emitted from the Optem® FUSION Illuminators. Under some circumstances, the high intensity light could cause eye injury. Furthermore, the Optem® FUSION Illuminators supports strobed operation. Photosensitive individuals may be affected by strobe lighting, which can lead to epileptic seizures or other undesirable sensations.*

---

The Optem® FUSION Illuminators are controlled by the Optem® FUSION Controller, which provides the unit with power and also controls the LED's intensity, timing, and mode of operation (i.e., DC, Pulse Width Modulation, Pulse Follow and Pulse Trigger modes).

---

**NOTE:** *Refer to the MAN-350013 Optem® FUSION Controller User Guide for more information.*

---

---

## Intended Use

The Optem® FUSION Illuminators are intended to be used as a component within a microscopy system such as the Optem® FUSION micro-imaging lens system. The Optem® FUSION Illuminators also interface with Optem® FUSION Fixed Magnification or Zoom Tube Lenses, and the Optem® FUSION Focus module. The Optem® Fusion Focus module includes a 50/50 beamsplitter to couple the illuminator to the optical path.

## Regulatory Compliance

The Optem® FUSION Illuminators have been tested and certified to comply with the IEC 62471 (photobiological safety of lamps and lamp systems) standard. Specifically it specifies the exposure limits, reference measurement technique, and classification scheme for the evaluation and control of photobiological hazards from all electrically powered incoherent broadband sources of optical radiation, including LEDs but excluding lasers, in the wavelength range from 200 nm through 3000 nm.

The Optem® FUSION Illuminators have been tested and certified to comply with the IEC 61326-1:2012/EN 61326-1:2013 Basic Electromagnetic Environment Emissions & Immunity for Measurement, Control, and

Laboratory Use Electrical Equipment. They also comply with IEC 61010-1/EN 61010-1:2010/A1:2019 Safety Requirements for Electrical Equipment for Measurement, Control, and Laboratory Use.

---

**NOTE:** *If the product is modified or changed, the FCC and/or CE approval becomes invalid. In this case, you are responsible for ensuring product conformity.*

---

---

## Changes to Excelitas Products

Excelitas reserves the right to improve, change, or modify products without incurring any obligations to make changes to previous Excelitas equipment.

---

## Technical Support

For technical support, please contact our Technical Support Team at [Inspection@excelitas.com](mailto:Inspection@excelitas.com).

---

## Limited Warranty Information

Excelitas Technologies Corp. (“Excelitas”) warrants that the enclosed Excelitas component(s) and related Excelitas accessories (individually a “Product” and collectively the “Products”) will be free from defects in materials and workmanship under normal use and service for a period, beginning from the date of shipment, of twelve (12) months.

Excelitas, at its sole discretion, will repair, replace, or adjust the defective Product, provided that Excelitas' investigation and factory inspection disclose that:

- such defect developed under normal and proper use, and
- the Product is covered under this limited warranty.

## Warranty Repair Process

Unless otherwise arranged by Excelitas, all service and support requests and Return Material Authorization (RMA) requests must be directed to the Excelitas customer support team, who are responsible for conducting preliminary analysis of issues and leading the investigation on all returned Product(s). The Excelitas customer support team, or another Excelitas officer, will issue a RMA number at its discretion if the analysis performed meets the criteria for RMA. This includes Original Warranty claims, Out of Box failures and Post Warranty service requests.

For complete warranty information, limitations, coverage, and process refer to the sales terms and conditions.

## CHAPTER

# 2

# General Description

The chapter provides a general description of the Optem® FUSION 1.5 A and 3 A Illuminator components and sub-components.

The following topics are covered:

- **Main Components, pg. 18**
  - Illuminator Cable, pg. 19
- **Adjusting Optics, pg. 20**
  - Adjusting Optics to Provide Kohler illumination, pg. 20
  - Adjusting Optics for Lower Lenses to Obtain Best Illumination, pg. 22

## Main Components

There are two versions of the Optem® FUSION Illuminator, a 1.5 A version (see [Figure 1](#)) and a 3 A version (see [Figure 2](#)). Typically, one 1.5 A LED illuminator is used with the system for illumination.

The Optem® FUSION Illuminators are controlled by the Optem® FUSION Controller, which provides the unit with power and also controls the LED's intensity, timing, and mode of operation (i.e., Continuous, Pulse Width Modulation, Pulse Follow and Pulse Trigger modes). The controller can support one 3.0 A LED illuminator or two 1.5 A LED illuminators. For more information regarding the Operational Modes, Controller Interfacing, and Software refer to *MAN-350013 Optem® FUSION Controller User Guide*.

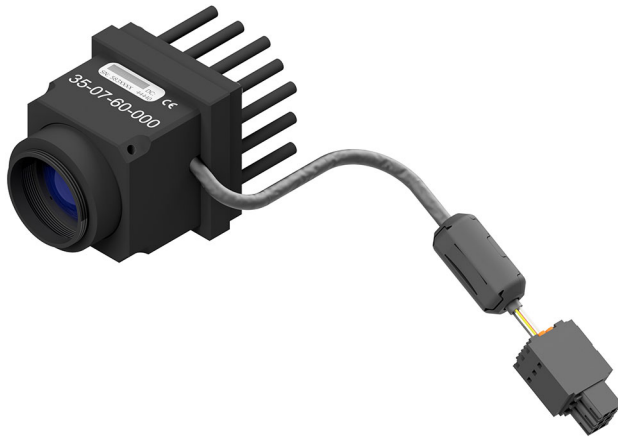

**Figure 1** Optem® FUSION Illuminators – 1.5 A



**Figure 2** Optem® FUSION Illuminators – 3 A

## Illuminator Cable

The Optem® FUSION Illuminators includes a hard-wired 1800 mm cable (not shown) to connect to the Optem® FUSION Controller (see "[Optem® FUSION Illuminators – 1.5 A Unit Dimensions](#)" on page 24 and "[Optem® FUSION Illuminators – 3 A Unit Dimensions](#)" on page 25). This section provides information on handling the illuminator cable and connector pin assignments (see [Table 2](#) and [Table 3](#)).

---

**WARNING!** Do not unplug the illuminator while the illuminator is on!

---



---

**WARNING!** Always connect the illuminator before powering up the controller!

---

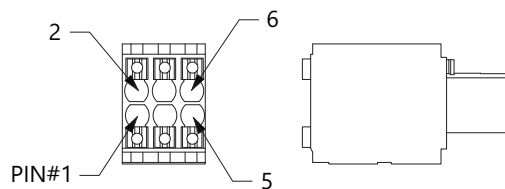

**Figure 3** Optem® FUSION Illuminators Connector Pin Out (1.5 A and 3 A)

**Table 2** 1.5A LED Driver Connector Pin Assignments

Pin	Signal	Description
1	LED1 Anode	LED1 Anode current output
2	LED2 Anode	LED2 Anode current output
3	NC	Not Connected, do not connect
4	NC	Not Connected, do not connect
5	LED1 Cathode	LED1 Cathode (return)
6	LED2 Cathode	LED2 Cathode (return)

**Table 3** 3A LED Driver Connector Pin Assignments

Pin	Signal	Description
1	LED Anode	LED Anode current output
2	LED Anode	LED Anode current output
3	NC	Not Connected, do not connect

**Table 3 3A LED Driver Connector Pin Assignments (continued)**

Pin	Signal	Description
4	NC	Not Connected, do not connect
5	LED Cathode	LED Cathode (return)
6	LED Cathode	LED Cathode (return)

---

## Adjusting Optics

Adjust the Optem® FUSION Illuminators so that the back focal plane of the microscope objective lens is illuminated properly by performing the following procedures.

### Adjusting Optics to Provide Kohler illumination

To adjust optics to provide Kohler illumination:

1. Connect power to the microscope system.

- The Illuminator body has four threaded holes, and two of them will have set screws that hold the lens compartment and LED compartment together in place. If set screws are not visible from outside, identify them using a 1.5 mm Allen key and loosen both of them to allow LED compartment to move freely.

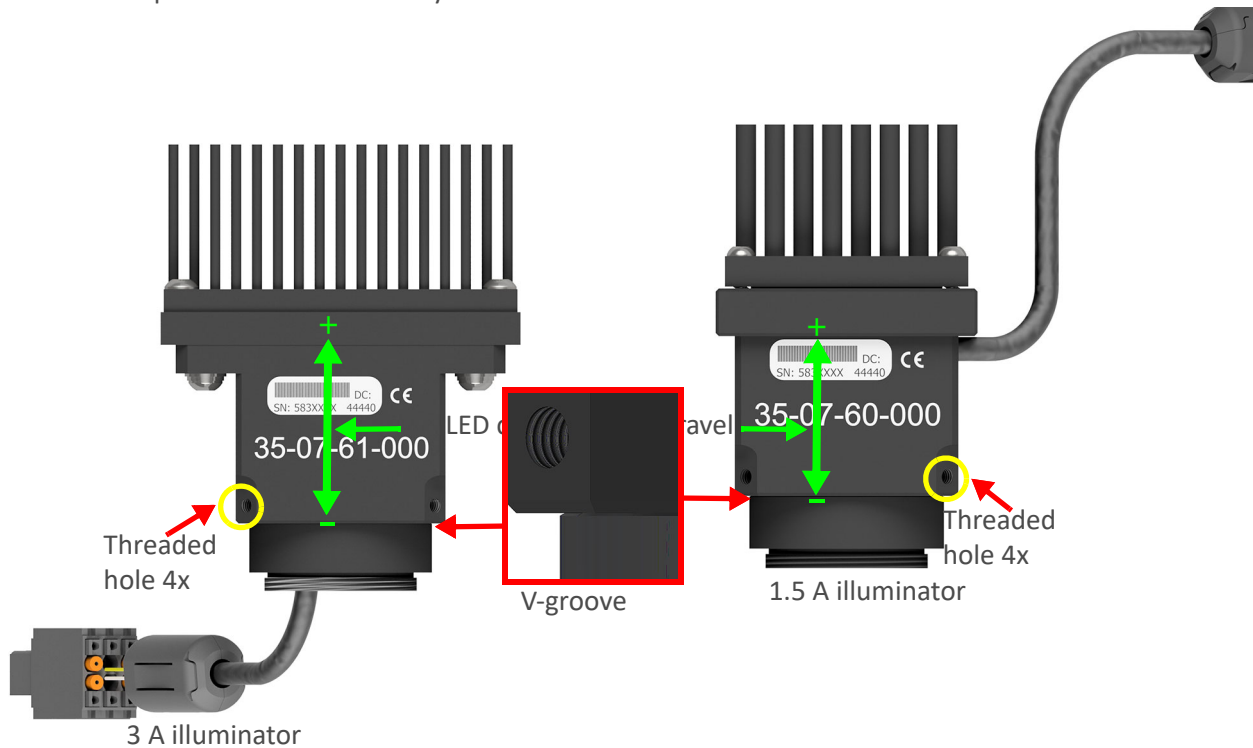

**Figure 4** *Adjusting the Illuminator Assembly Optics*

- To align the illuminator for the Optem® FUSION 10x M Plan objective, adjust the position of the illuminator until the middle of V-groove on the lens compartment is aligned with the LED compartment as shown in [Figure 4](#).
- For other Optem® FUSION objectives (other than 10X M PLAN) indicated in [Table 4](#), the LED compartment must be moved gently in either the + and - direction.

---

**NOTE:** [Table 4](#) serves as a guideline to optimize illumination uniformity. Exact movement is not necessary, instead optimization by visual inspection is recommended.

---

**NOTE:** + means that the LED compartment is pulled back from the microscope body. - means that the LED compartment is pushed towards the microscope body as shown in [Figure 4](#).

**Table 4 LED Compartment Adjustment For Typical Optem® FUSION Objectives**

Optem® FUSION Objective	LED compartment adjustment from nominal position (V-groove)
2X M PLAN	+1.00 mm
5X M PLAN	+0.40 mm
10X M PLAN	+0.00 mm (V-Groove)
20X M PLAN	+0.09 mm
50X M PLAN	-0.07 mm
5X HR	-0.30 mm
10X HR	-1.17 mm
20X HR	-0.32 mm

- Using a 1.5 mm Allen key, tighten the set screws in place once the correct position for the illuminator is achieved.

## Adjusting Optics for Lower Lenses to Obtain Best Illumination

To adjust optics to obtain best Illumination:

- Perform [step 1](#) and [step 2 on page 21](#).
- The v-groove can be considered as the nominal position and by moving the LED compartment in + and - directions, you can set the position based on your imaging needs.

**NOTE:** There will be a compromise between high intensity illumination in the FOV center and light intensity uniformity over the entire FOV.

- Using a 1.5 mm Allen key, tighten the set screws in place once the correct position for the illuminator is achieved.

## CHAPTER

# 3

# Specifications and Dimensions

This chapter provides the Optem® FUSION 1.5 A and 3 A Illuminator's mechanical and optical specifications and dimensions.

The following topics are covered:

- [Mechanical Specifications, pg. 24](#)
- [Electrical Specifications, pg. 26](#)
  - [Electrical Characteristics, pg. 26](#)
- [Optical Specifications, pg. 27](#)
- [Environmental Specifications, pg. 28](#)

# Mechanical Specifications

The following figures highlight the mechanical specifications of the Optem® FUSION Illuminators.

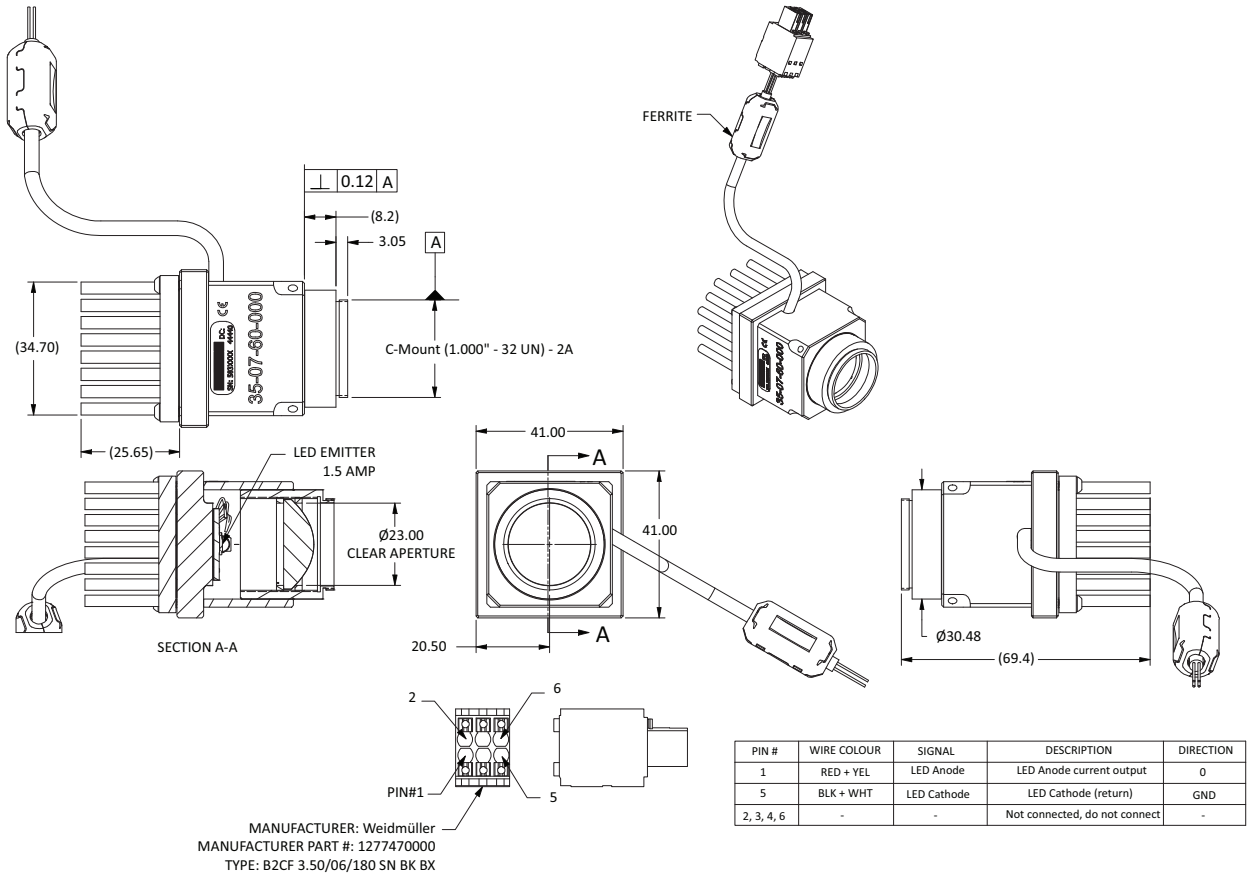

Figure 5 Optem® FUSION Illuminators – 1.5 A Unit Dimensions

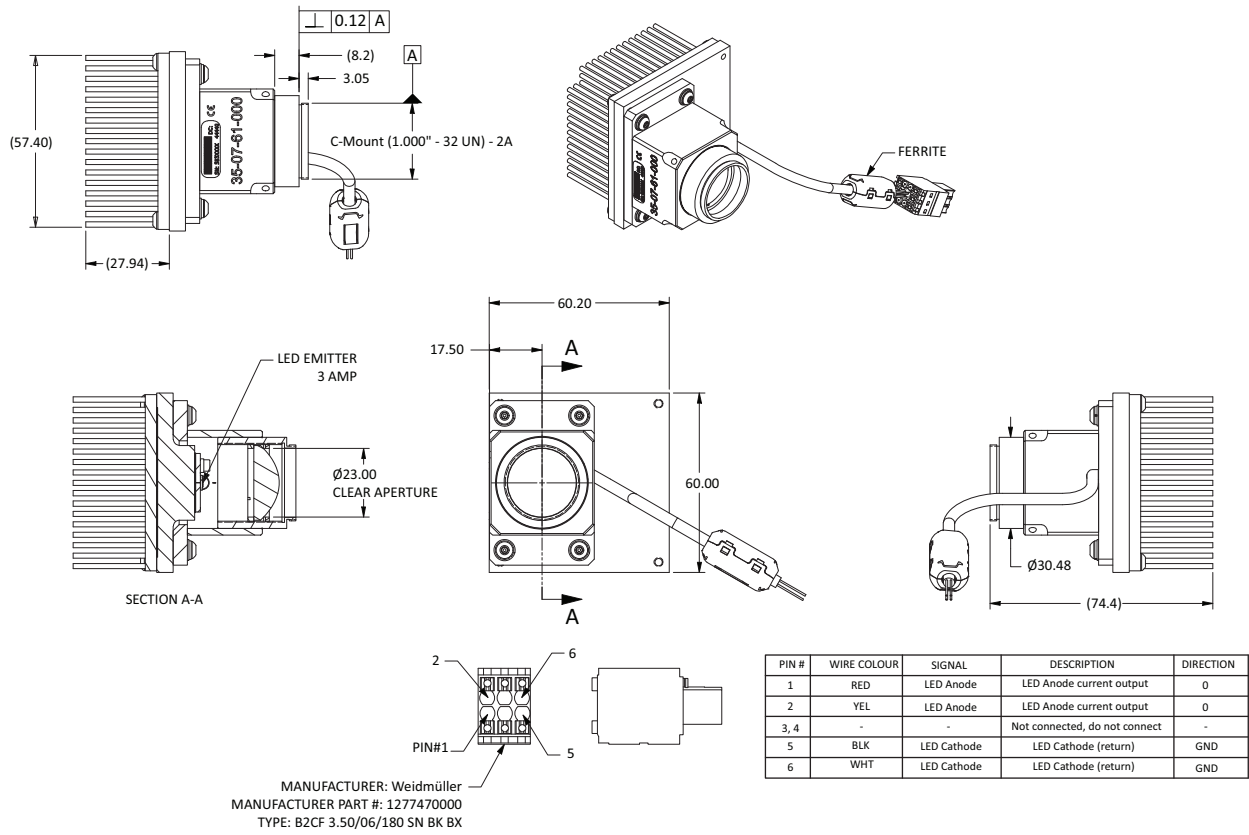

Figure 6 Optem® FUSION Illuminators – 3 A Unit Dimensions

## Electrical Specifications

The following section highlights the electrical specifications of the Optem® FUSION Illuminators.

### Electrical Characteristics

The electrical characteristics for the Optem® FUSION Illuminators are provided in [Table 5](#).

**Table 5 Optem® FUSION Illuminators Electrical Characteristics**

Parameter	Condition	Min	Typical	Max	Units
<b>Dual Channel LED Driver, Each Channel</b>					
Forward Voltage		5.25	5.72	6.25	V
Forward Current 1.5A		0.2		1.5	A
Forward Current 3A		0.2		3.0	A

## Optical Specifications

This section provides the optical specifications of the Optem® FUSION Illuminators.

**Table 6 Luminous Flux Parameters**

Parameter	Value
Illuminance @ 81.4 mm:	1.5A >500 klux
Illuminance @ 81.4 mm:	3.0A >1000 klux
Color temperature	6500 K
Typical spectrum	See <a href="#">Figure 7</a>

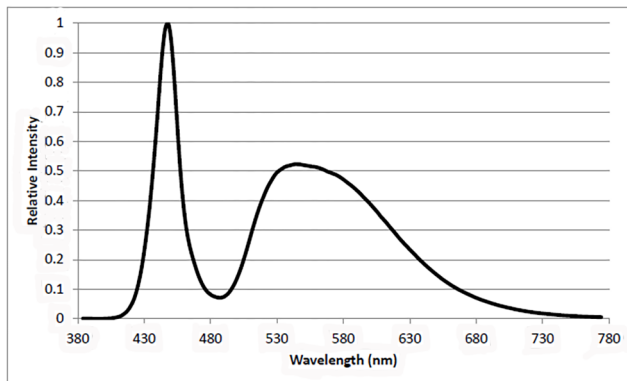

**Figure 7** Typical Spectrum

---

## Environmental Specifications

---

**NOTE:** *Excelitas takes no responsibility for poor performance or malfunction of the system if the conditions described in this section are not met.*

---

The Optem® FUSION Illuminators is intended to be operated and stored under the following conditions:

- 1) In a non-corrosive clean room, laboratory, or factory environment having Class 100,000 (ISO8) or better.
- 2) Operating Environment:
  - The modules shall operate and meet all performance requirements in the operating range 10°C to 40°C, and a humidity range of 10% to 75% non-condensing.
- 3) Non-Operating (Storage) Environment:
  - The modules shall meet all performance requirements after being stored in the non-operating environment from 0°C to 45°C.
- 4) Non-Operating (Transport) Environment:
  - The modules shall meet all performance requirements after being transported in the non-operating environment from -25°C to 70°C. Devices shall not be stored in this range for an extended period of time.

# Index

## A

acronyms, list 10  
adjust focus 21

## C

color temperature 27

## D

dimensions  
  illuminator 1.5A 24  
  illuminator 3A 25

## E

electrical characteristics 26  
environmental conditions 28

## F

flux parameters, luminous 27  
focus, adjust 21

## I

Illuminance 27  
illuminator  
  environmental conditions for 28  
intended use, of illuminator 14

## S

specifications  
  electrical 26  
  environmental 28  
  mechanical 24  
  optical 27  
specifications, optical 27

## T

technical support, contacting 15  
typical spectrum 27

## W

warning labels 10