

35-07-60-000 – 1.5A High Power Coaxial LED Illuminator Optem® FUSION



Features

- Ultra High-power white light LED
- Available in 1.5A and 3A
- 6500K Correlated Colour Temperature
- Greater than 50K hour lifetime
- Direct integration to FUSION coaxial modules
- Full SW support with FUSION Controller
- PWM or constant current control with FUSION Controller
- Adjustable PWM frequency 1.5-100000 Hz.
- Adjustable lens to optimize illumination uniformity
- Other colour LEDs available upon customer request

Optem® FUSION 1.5A and 3A Coaxial Illumination Modules

The high-power LEDs feature a compact industrial design optimized to deliver ultra-high uniform illuminance critical for the most challenging machine vision applications. An integrated adjustable lens allows fine-tuning the illumination uniformity.

The high-power LEDs seamlessly integrate into the Optem® FUSION micro-imaging platform, extending the modular nature of the platform. Combined with the FUSION Controller, the LEDs offer adjustable software control for pulse width modulation and constant current control.

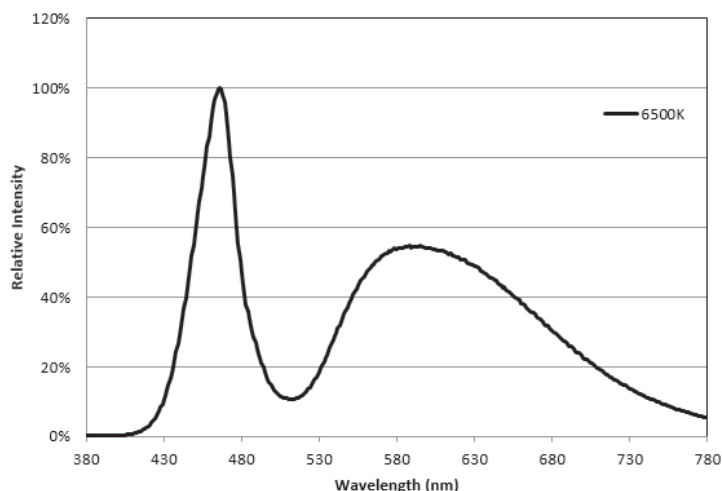

Applications

- High throughput micro-imaging
- High precision manufacturing
- Automated Optical Inspection
- Quality control
- Semiconductor
- MEMs
- Bio-imaging
- Metrology
- R&D and Laboratory

35-07-60-000 – 1.5A High Power Coaxial LED Illuminator

Optem® FUSION

Specifications

Parameter	1.5A	3.0A	Units
Wavelength	White LED	White LED	-
Correlated Colour Temperture (CCT)	6500	6500	K
Lifetime	>50000	>50000	Hours
Illuminance (70mm from lens output)	3.4	6.0	MLux
Illuminance (through 50/50 at back aperture of objective)	1.7	3.0	MLux
Maximum Current	1.5	3.0	A
Control (with FUSION Controller)	PWM or Current	PWM or Current	-

Notes: ¹

Dimensions

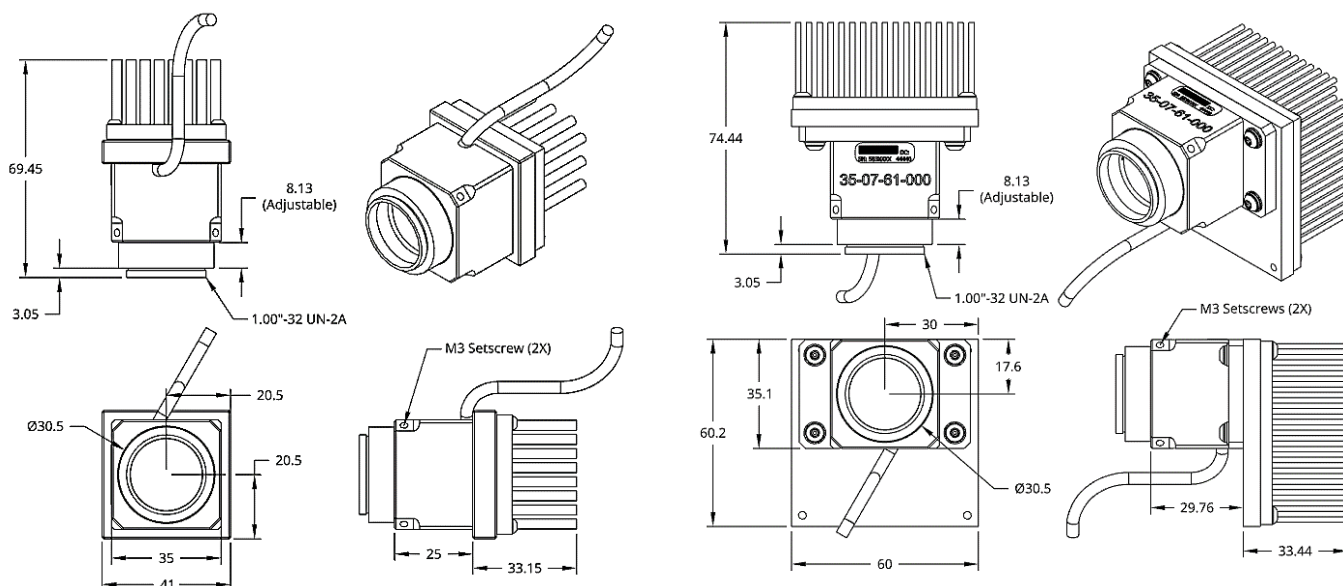

About Excelitas

Excelitas is a leading industrial technology manufacturer focused on delivering innovative, market-driven photonic solutions to meet the illumination, optical, optronic, sensing, detection and imaging needs of our OEM and end-user customers.

Serving a vast array of applications across biomedical, scientific, semiconductor, industrial manufacturing, safety, security, consumer products, defense and aerospace sectors, Excelitas stands committed to enabling our customers' success in their many various end-markets.

Excelitas Technologies Corp.
22001 Dumberry Road
Vaudreuil-Dorion, Quebec
Canada J7V 8P7
Tel.: (+1) 450.424.3300
Toll-free: (+1) 800.775.6786

Inspection@excelitas.com

Excelitas Deutschland GmbH
Hans-Riedl-Str. 9
D-85622 Feldkirchen
Germany
Telephone: +49 (0) 551 6935-0

Inspection@excelitas.com

**Excelitas Technologies
Singapore, Pte. Ltd.**
8 Tractor Rd
Singapore 627969
Singapore
Telephone: +65 64 99 7777

Inspection@excelitas.com



For a complete listing of our global offices, visit www.excelitas.com/locations

© 2015 Excelitas Technologies Corp. All rights reserved. The Excelitas logo and design are registered trademarks of Excelitas Technologies Corp. All other trademarks not owned by Excelitas Technologies or its subsidiaries that are depicted herein are the property of their respective owners. Excelitas reserves the right to change this document at any time without notice and disclaims liability for editorial, pictorial or typographical errors.