



I250 P/W



I250



F10T

Fusion UV[®] DRF UV Curing Systems for Optical Fiber, Coloring, Ribbon, and Cable

The DRF lamp has been the UV curing system of choice for optical fiber manufacturing and coating operations around the world. This success is due to the unique optical system incorporated in the lamp, which delivers highly focused, intense UV energy.

These lamps are used for curing photoresponsive coatings, coloring inks, and ribbon matrix polymers. High power and high intensity (irradiance) provide the UV curing energy to meet the sustained high speed demands in today's production environment.

Microwave-powered Lamp

At the heart of the lamp is the Fusion UV microwave-powered electrodeless bulb. Power stability and spectral consistency over long periods of time are the hallmarks of the microwave-powered lamp system.

Modular Lamps

The modular design facilitates easy maintenance and replacement. Modular power supplies can be grouped for electrical control simplicity. Control flexibility is enhanced by the modular design, easy control settings, and prewired interconnections.

Fusion UV[®]

excelitas[®]

6" System

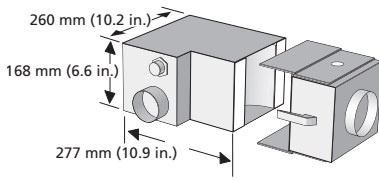

I300 P/W

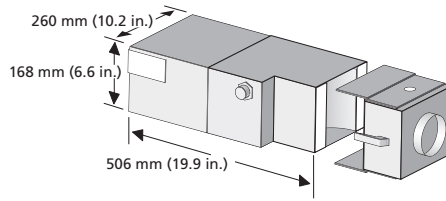

I300 B/W

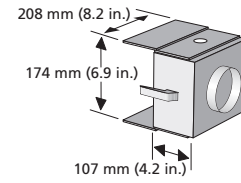

F6

Interchangeable Bulbs

A variety of bulbs is available, each having a characteristic UV spectral output, allowing the matching of bulb energy to the photochemical response to yield the highest cure efficiency.

High Efficiency Reflectors

An optional, patented back reflector collects light energy and delivers it uniformly around the target, substantially increasing the efficiency of the full elliptical reflector. In combination with the small diameter, high radiance bulbs, this reflector system produces the highest UV irradiance per watt of power of any lamp system.

The Following Reflector Systems are Available:

- **R500:** High reflectance over the entire spectral range;
- **Dichroic:** Enhanced UV reflectance, removes most visible and infrared energy.

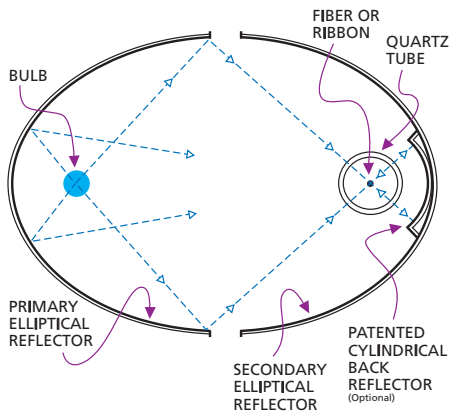

F10T and F6 Reflector System

The housing, which holds the secondary elliptical reflector, quartz tube, attachments and fittings (such as nitrogen connection), is designated F10T (for 10-inch lamps) or F6 (for 6-inch lamps). This housing attaches to the lamp housing by means of clamp-action latches to achieve the optics of a full elliptical system. The electrodeless bulb is located at the primary focus (in the irradiator), and the product runs through the secondary focus. The accuracy and repeatability of the attachment to the lamp is governed by hard metal stops and pins. The F10T2 model separates differently than the F10T, in a manner that the fittings and quartz tube remain in place on the lamp assembly.

D Bulb (13 mm)

Radiated Power, W/10 nm

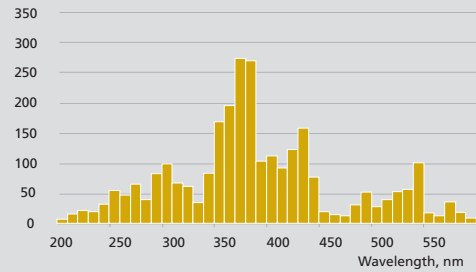

H Bulb (13 mm)

Radiated Power, W/10 nm

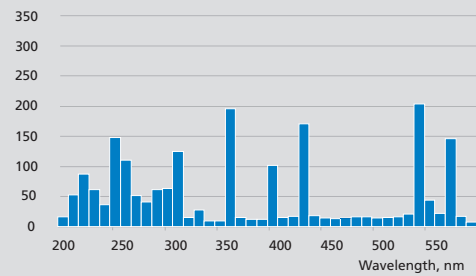

V Bulb (13 mm)

Radiated Power, W/10 nm

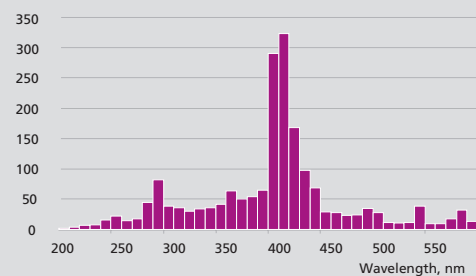

10" System

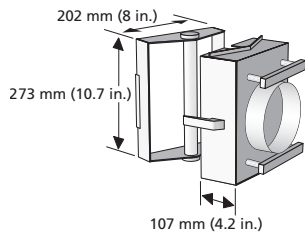

F10T2

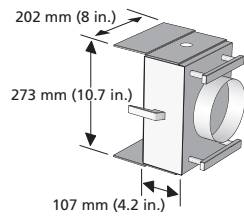

F10T

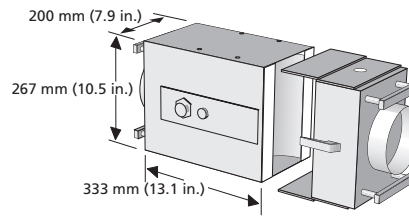

I250 P/W

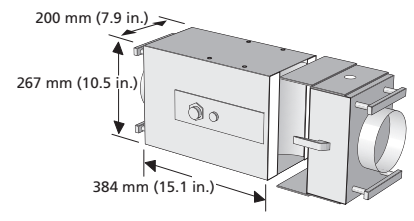

I600 P/W

F10T2 Reflector System

A variation of the standard F10T. Its design provides the following benefits:

- A fixed skirt provides additional light shielding and end fittings for the quartz tube, which remains in place when the F10T2 is detached.
- Easily remove 10" quartz tube from the front.
- The fixed quartz tube allows observation of the product in place, condition of quartz tube, and reflector.

Available for all Fusion UV Lamps:

- **F300S:** 1.8 kW, 6-inch (300 watt/inch) lamps are compact, ideal for small systems;
- **LightHammer® 6 Mark II:** 3 kW, 6-inch (500 watt/inch) lamps are compact, high power and come with a solid-state variable power supply;
- **LightHammer® 10L Mark II:** 3 kW, 10-inch (300 watt/inch) lamps provide the highest irradiance per watt of any lamp system; with a solid-state variable power supply;
- **F600S, LightHammer® 10H Mark II:** 6 kW, 10-inch (600 watt/inch) lamps provide higher total power and a larger target size. Two-power level control (F600S) or variable power control (LightHammer® 10 Mark II) are available.

Quick Start

The microwave-powered lamp is well known for its ability to develop full power output within a few seconds. It can turn off instantly and restart almost immediately.

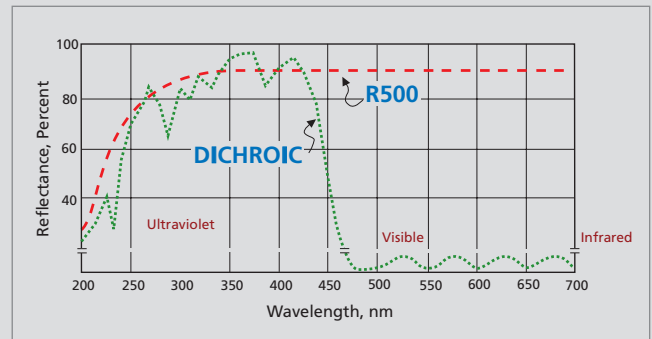

10-INCH LAMPS

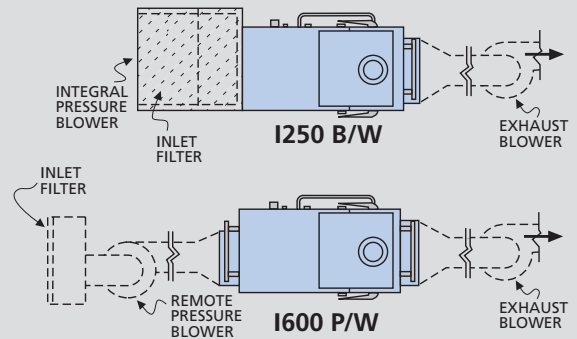

6-INCH LAMPS

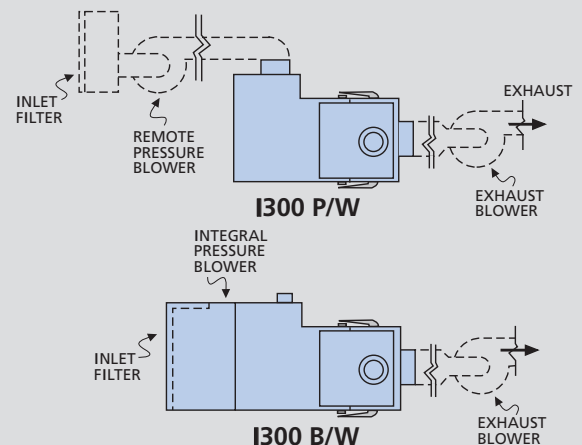

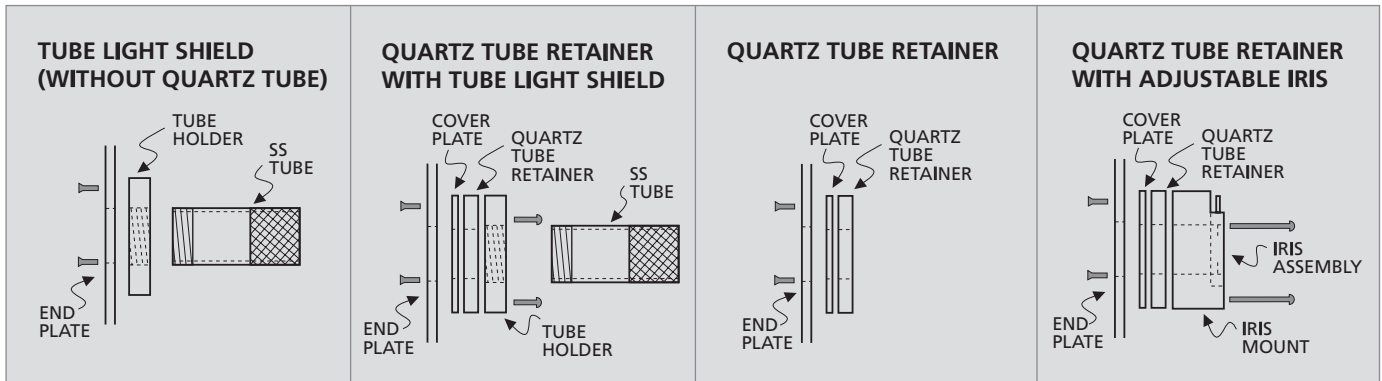

Air-cooled System

The microwave-powered lamp is air cooled; push-pull cooling is recommended. The quartz tube is held by a Teflon® gasket which seals it from outside air. The lamp and reflector system are cooled by means of both positive and negative-pressure blowers, which direct the cooling air through the lamp.

Multiple Power Levels

Several systems can operate at multiple power levels: The F600S system provides a user-selectable setting of 65% and 100% of full power to the irradiator. The LightHammer® 10 Mark III power supply provides continuously adjustable power in the range of 35% to 100% of full power.

In a multi-lamp system, any lamp can be switched on or off, providing an even wider range of power control. Lamp modules can be energized in sequence and coordinated with line speed.

End Plates

The F10T, F10T2, and F6 housings are equipped with flat end plates, to which fittings and attachments are mounted. A variety of fittings may be selected and supplied by Fusion UV, or may be user-designed.

Lamps contain mercury. Manage in accordance with local, state or federal disposal laws.

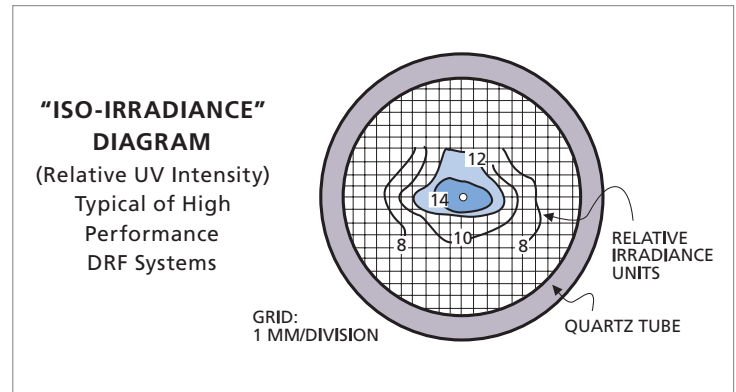

End Fittings Available

A number of end fittings and options are available, which include sealing and support rings for quartz tubes, nitrogen ports, adjustable irises for light shielding, and straight tube light shields.

Lamp Mounting and Alignment

Lamps can be mounted and operated in any position. The lamp housing has two sets of four threaded inserts for easy attachment to the lamp mounting and alignment plate of the user's machine. An Easy Align lamp mounting system is also available as an option to ensure accurate alignment during lamp replacement.

Contact your local Excelitas Fusion UV office for an engineered solution for your specific requirements.



www.excelitas.com info.hna@excelitas.com

ISO 9001 Certified QMS

