



C30683-1550 Series



InGaAs APD with Transimpedance Amplifier

Excelitas Technologies' C30683-1550 series includes an InGaAs Avalanche Photodiode (APD) with a TIA, in a hermetically sealed TO-8 package, to allow for low-noise operation. This device is designed for high-speed, extreme low-light detection and free-space optical communication.

The InGaAs APDs used in the C30683-1550 series are the same as used in Excelitas' C30645 and C30662 products. These detectors provide very good response between 1100 and 1700 nm and a very fast risetime. The preamplifier section of the module uses a very low noise TIA that can operate at high speeds with a bandwidth up to 450 MHz.

The C30683-1550 features an internal thermistor to be used for the temperature compensation of the HV supply in order to maintain a constant responsivity.

Customization of the C30683-1550 Series of APD Preamplifier Modules is available to meet your specific design challenges; modifications include bandwidth and gain optimization, use of different APDs, and FC-connectorized packaging.

APPLICATIONS

- Analytical Instrumentation
- LiDAR and Range Finding
- Distributed Temperature Sensing (DTS)
- Confocal Microscopy

YOUR BENEFITS

- InGaAs APD integrated with first gain stage in hermetically sealed TO package
- High system bandwidth up to 450 MHz
- Low noise equivalent power (NEP) of $250 \text{ fW}/\sqrt{\text{Hz}}$
- High responsivity of 120 kV/W at 1550 nm

SPECIFICATIONS

- 80 and 200 μm InGaAs APD
- Responsivity of 120 kV/W at 1550 nm
- 50 Ω AC load capability (AC-coupled)
- +3.3 V amplifier operating voltage
- Differential Output

Ordering Guide

Model	Nominal Bandwidth	Wavelength Response	APD Model	APD Material	APD Active Diameter
C30683-1550-R08DH	450 MHz	1550 nm	C30645	InGaAs	0.08 mm
C30683-1550-R2BH	300 MHz	1550 nm	C30662	InGaAs	0.2 mm

Electro-Optical Specifications

All specifications are referring to an ambient temperature of $T_A = 23^\circ\text{C}$, $\lambda = 1550\text{ nm}$, $HV = V_{op}$ (see note 1), $V_{amp} = +3.3\text{ V}$, $R_L = 50\ \Omega$ AC coupled unless otherwise specified.

Detector	Parameter	Symbol	C30683-1550-R08DH (C30645, 80 μm , 1550nm)			C30683-1550-R2BH (C30662, 200 μm , 1550nm)			Units
			Min	Typ	Max	Min	Typ	Max	
Active Diameter	d			0.08			0.2		mm
Active Area	A			0.005			0.03		mm ²
Bandwidth	B		300	450		200	300		MHz
Operating Voltage	V_{op}			70			70		V
Temperature Coefficient of V_{op} for constant gain	$\Delta V/\Delta T$			0.14			0.14		V/ $^\circ\text{C}$
Responsivity at 1550 nm	R_{1550}		100	120		100	120		kV/W
Noise Equivalent Power (note 2)	NEP			250		470	250		fW/ $\sqrt{\text{Hz}}$
Output Spectral Noise Voltage (note 3)	V_n			30		70	30		nV/ $\sqrt{\text{Hz}}$
Output Impedance	Z			50			50		Ω
DC Output Offset Voltage (note 4)	V_{oo}		1.2	1.34		1.2	1.34		V
Positive Supply Current	I_{amp}			100		120	100		mA
Thermistor Resistance (note 5)	R_{th}			10 \pm 5%			10 \pm 5%		k Ω

Notes:

1. A specific value of V_{op} is supplied with each device. The V_{op} value will be within the specified range.
2. NEP is calculated as the output spectral noise voltage divided by the typical responsivity and $\Delta f = 1.0\text{ Hz}$ at 1550 nm.
3. Average from 100 kHz to f_{-3dB} .
4. Pulsed operation.
5. The temperature of the thermistor in Kelvin can be calculated using the following equation:

$$T[K] = \frac{\beta}{\ln\left(\frac{R_{th}}{r_{\infty}}\right)} \text{ where } \beta = 3890\text{ K}, R_0 = 10000\ \Omega, T_0 = 298.15\text{ K and } r_{\infty} = R_0 e^{\frac{-\beta}{T_0}} \approx 0.0215\ \Omega.$$

Maximum Ratings

Parameter	Symbol	Min	Max	Units
Storage Temperature	T_s	-40	125	$^\circ\text{C}$
Operating Temperature	T_{op}	-40	125	$^\circ\text{C}$

FIG 1. TYPICAL RESPONSIVITY AND QUANTUM EFFICIENCY

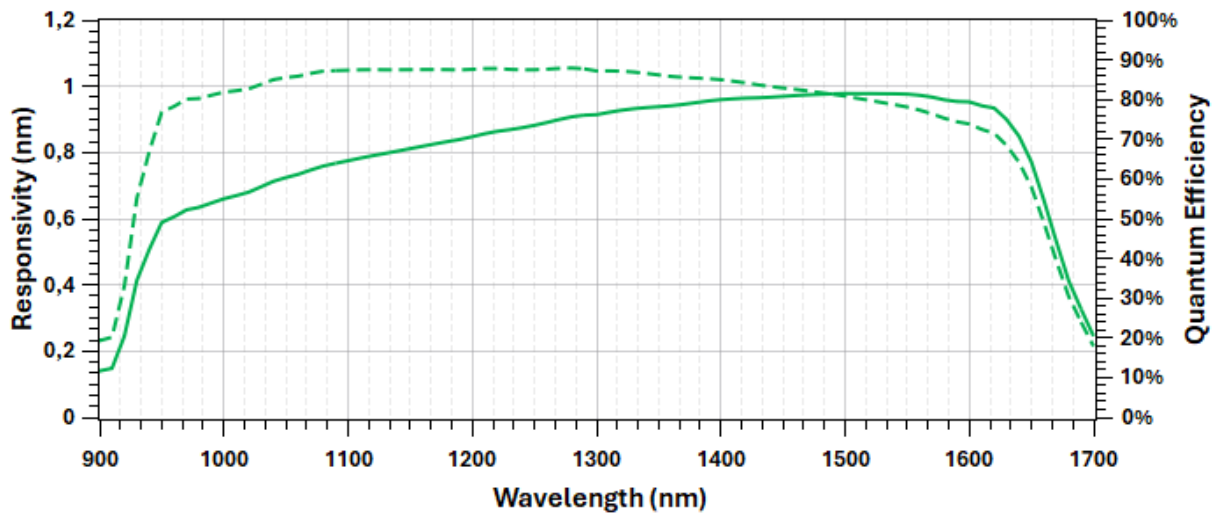
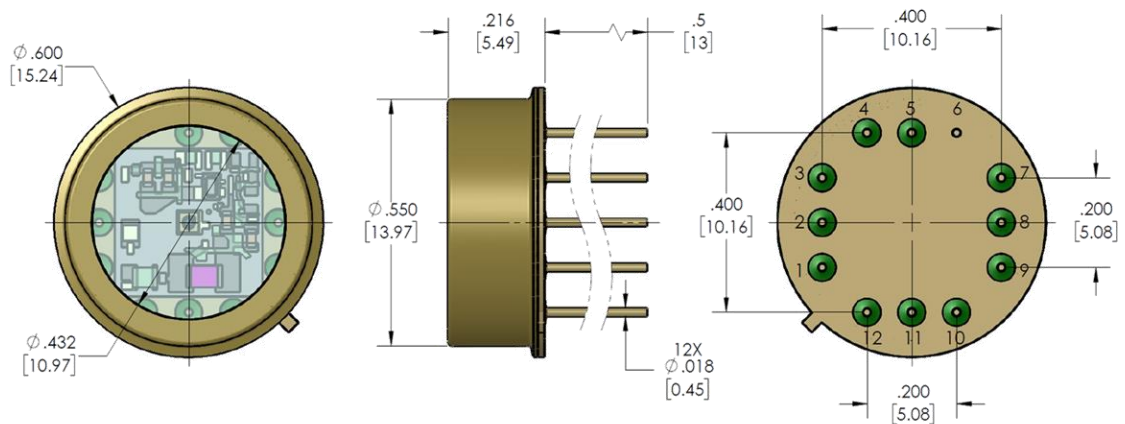

FIG 2. MECHANICAL DIMENSIONS AND PINOUT



PIN OUT DESCRIPTION			
PIN #	DESC	PIN #	DESC
1	NC	7	VCC2
2	VCC1	8	TS2
3	NC	9	TS1
4	OUTN	10	HV-
5	OUTP	11	NC
6	CASE / GND	12	NC

DIMENSIONS ARE IN INCHES [MILLIMETERS]
AND ARE FOR REFERENCE ONLY

Testing and operation methods

Excelitas verifies the electro optical specifications on every device. Hence, a specific voltage, V_{OP} , is supplied with each device. When the device is operated at this voltage (at 22 °C), it will meet the electrical specifications shown above.

Visual inspection during fabrication is performed as per our quality standard and failed parts are removed.

Excelitas Technologies is certified to meet ISO-9001 and are designed to meet MIL-STD-883 and/or MIL-STD-750 specifications.

Packaging and shipping

Parts are shipped in sealed plastic trays.

Storage and handling

Excelitas highly recommends to keep the devices in an ESD controlled environment until final assembly.

RoHS compliance

The C30683-1550 series is designed and built to be fully compliant with the European Union Directive on restrictions on the use of certain hazardous substances in electrical and electronic equipment.



Warranty

A standard 12-month warranty following shipment applies



Excelitas Technologies

22001 Dumberry Road
Vaudreuil-Dorion, Quebec
Canada J7V 8P7
Telephone: (+1) 450.424.3300
Toll-free: (+1) 800.775.6786
Fax: (+1) 450.424.3345

**Excelitas Technologies
GmbH & Co. KG**

Wenzel-Jaksch-Str. 31
D-65199 Wiesbaden
Germany
Telephone: (+49) 611 492 430
Fax: (+49) 611 492 165

Excelitas Technologies Singapore, Pte. Ltd.

8 Tractor Road
Singapore 627969
Telephone: (+65) 6775 2022 (Main number)
Telephone: (+65) 6770 4366 (Customer Service)
Fax: (+65) 6778-1752

For a complete listing of our global offices, visit www.excelitas.com/locations

© 2025 Excelitas Technologies Corp. The Excelitas logo and design are registered trademarks of Excelitas Technologies Corp. Excelitas reserves the right to change this document at any time without notice and disclaims liability for editorial, pictorial or typographical errors.

C30683-1550 Series_Rev.2026.03.30