

LINOS Motorized Beam Expander

1x – 4x, 340 – 360nm, fused silica

Part number	4401-596-000-20 4401-596-000-21		
Design wavelength	λ	(nm)	355
Expansion	Γ'		1x – 4x
Lens material			Fused Silica
Material			Aluminum, colorless anodized; Premium Steel
Mechanical entrance aperture diameter		(mm)	8.7
Max. entrance beam diameter ($1/e^2$) for magnification $1.0 \leq \Gamma \leq 3.0$	$E_{max} \varnothing$	(mm)	8.0
Max. entrance beam diameter ($1/e^2$) for magnification $3.0 \leq \Gamma \leq 3.5$	$E_{max} \varnothing$	(mm)	7.0
Max. entrance beam diameter ($1/e^2$) for magnification $3.5 < \Gamma \leq 4.0$	$E_{max} \varnothing$	(mm)	6.25
Max. exit beam diameter ($1/e^2$)		(mm)	25
Max. mechanical exit aperture		(mm)	31
Pointing Stability		(mrad)	< 0.3
Group delay dispersion at λ	GDD	(fs ²)	3114
Total transmission @ 340-360nm	T	(%)	> 96
Overall cleanliness of the system in accordance with DIN ISO 10110, viewed from the outlet side			15/ 16x0.063 L 5x0.016 (for all β)
LIDT coating @ 355nm, 6ns, 100Hz		(J/cm ²)	4
LIDT coating @ 343nm, 200fs, 1kHz		(J/cm ²)	0.4
Weight		(kg)	0.90
Protective glass	PG		4401-516-006-00
Interface/protocol: 4401-596-000-20			SubD9 / RS232
Interface/protocol: 4401-596-000-21			Phoenix Contact / RS232

Subject to technical change

Notes

For technical explanations, see our homepage.

[LINOS Laser Material Processing Optics | Excelitas](#)

The actual LIDT of the Beam Expander, as well as effects such as thermal focus shift, depend on the specific system setup and laser parameters. We recommend testing the respective optical components before use. We are happy to support and advise you in selecting the right Beam Expander!

Mechanical drawing: 4401-596-000-20

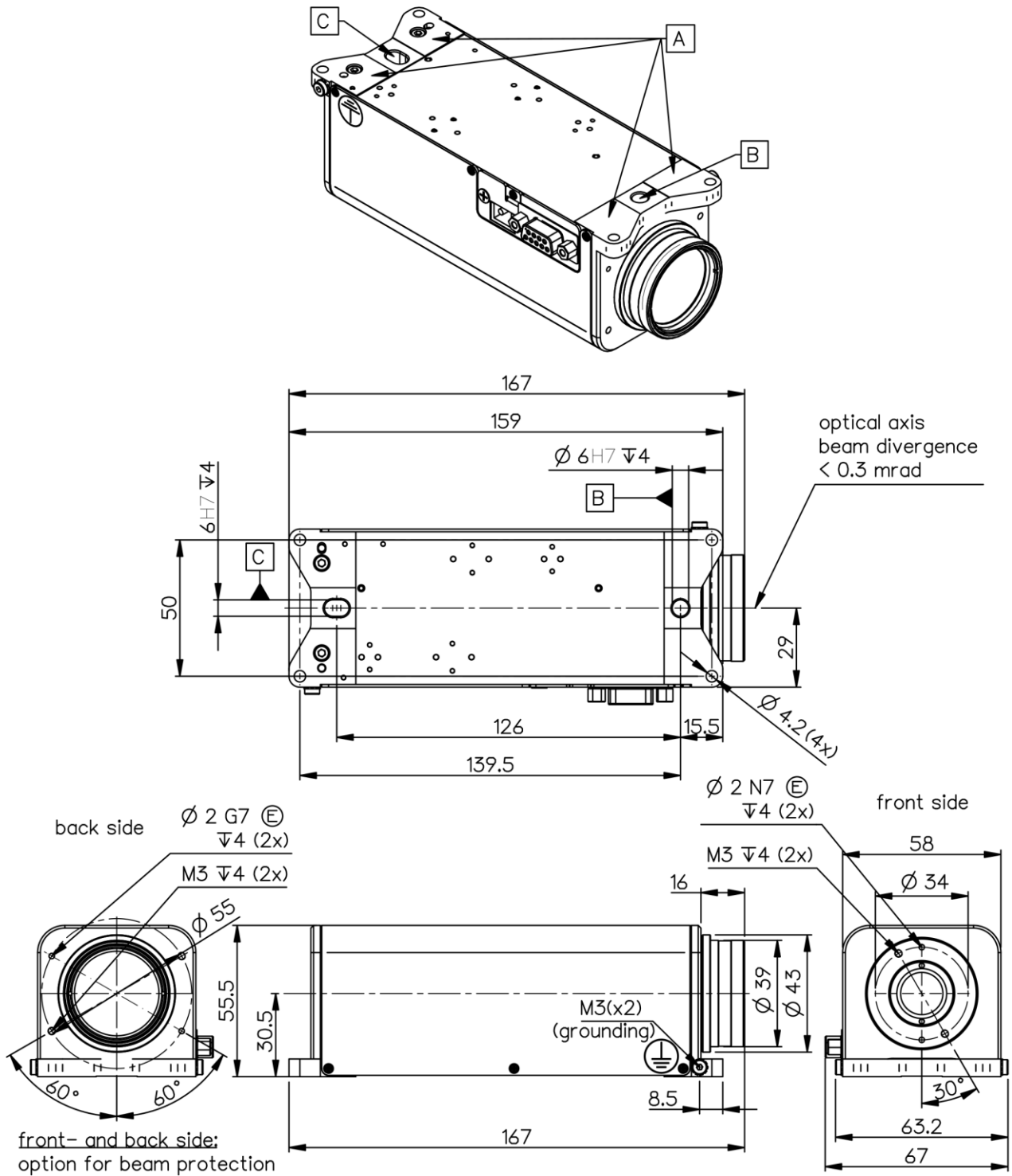

Mechanical drawing: 4401-596-000-21

