

45-04-40-000 – 10mm Motorized Focus with Coaxial Illumination, SWIR**Optem® FUSION**

Optem® FUSION focusing module providing automated high-precision focusing capabilities with coaxial illumination.

The Optem® FUSION motorized focus module delivers rapid high precision, repeatable focusing across travel ranges far greater than conventional piezo-driven solutions. Precision engineered with high durability ensures focus is maintained for the full life cycle of demanding high-throughput imaging applications

The focus module features a powerful stepper motor and precision guide, providing 10mm of focus travel and up to 0.039um/step resolution for objectives weighing up to 1000g.

The motorized focus module provides mounts for easy adoption of both coaxial (epi-) illumination and off-axis (ring) light illumination for critical illumination applications.

With seamlessly integration into the modular Optem® FUSION micro-inspection platform, a fully automated system including high-powered illumination and zoom is easily configured for OEM or benchtop applications across the visible to shortwave infrared (SWIR) wavelengths.

NOTE:

35-04-40-000 **Visible Version**
45-04-40-000 **SWIR Version**

Features

- Extended 10mm travel range
- Rapid high-precision repeatable focus
- High speed focusing (10mm/s velocity, 100mm/s² acceleration)
- Integrated coaxial beamsplitter for either VIS (400-700nm) or SWIR (633-1700nm) applications
- Objectives up to 1000g
- Easy mounting features for coaxial and ring light illumination
- Supports full range of Optem FUSION micro-inspection platform
- Seamless integration with FUSION automated modules/controllers
- Universal Ethernet connector

Applications

- Universal high throughput micro-imaging
- High precision manufacturing
- Automated Optical Inspection
- Quality control
- Semiconductor
- MEMs
- Bio-imaging
- Metrology
- R&D and Laboratory

45-04-40-000 – 10mm Motorized Focus with Coaxial Illumination, SWIR

Optem® FUSION

Specifications

Parameter	Minimal	Typical	Maximal	Units
Focus Travel Range		10 (±5)		mm
Resolution (Max)		0.039		um/μstep
Velocity		10		mm/s
Acceleration		100		mm/s ²
Maximum Load ¹		1000		g
Weight		559		g
Motor (Stepper)		2-Phase		-

Notes: ¹ Inverted is 500g

Dimensions

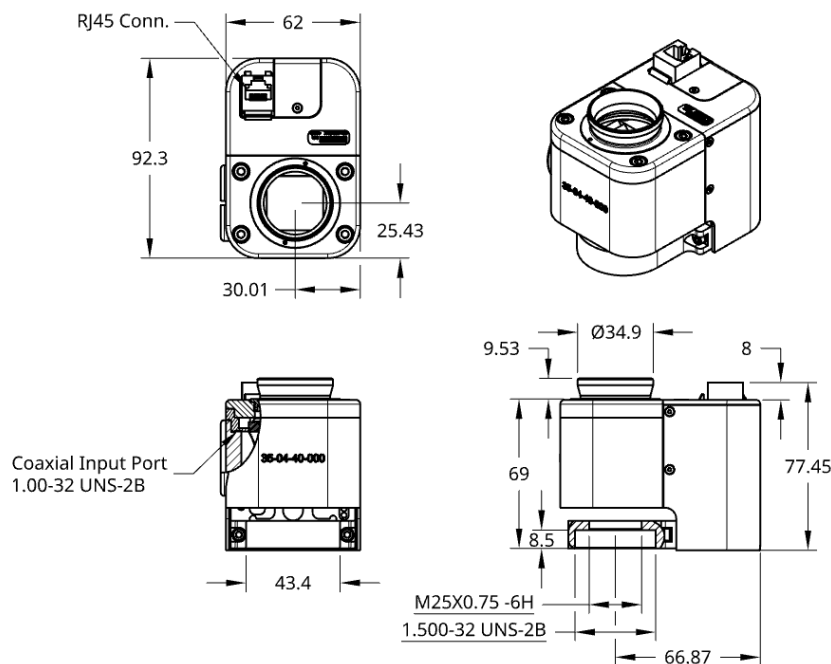

About Excelitas

Excelitas is a leading industrial technology manufacturer focused on delivering innovative, market-driven photonic solutions to meet the illumination, optical, optronic, sensing, detection and imaging needs of our OEM and end-user customers.

Serving a vast array of applications across biomedical, scientific, semiconductor, industrial manufacturing, safety, security, consumer products, defense and aerospace sectors, Excelitas stands committed to enabling our customers' success in their many various end-markets.

Excelitas Technologies Corp.
 22001 Dumberry Road
 Vaudreuil-Dorion, Quebec
 Canada J7V 8P7
 Tel.: (+1) 450.424.3300
 Toll-free: (+1) 800.775.6786

Inspection@excelitas.com

Excelitas Deutschland GmbH
 Hans-Riedl-Str. 9
 D-85622 Feldkirchen
 Germany
 Telephone: +49 (0) 551 6935-0

Inspection@excelitas.com

**Excelitas Technologies
 Singapore, Pte. Ltd.**
 8 Tractor Rd
 Singapore 627969
 Singapore
 Telephone: +65 64 99 7777

Inspection@excelitas.com



For a complete listing of our global offices, visit www.excelitas.com/locations

© 2015 Excelitas Technologies Corp. All rights reserved. The Excelitas logo and design are registered trademarks of Excelitas Technologies Corp. All other trademarks not owned by Excelitas Technologies or its subsidiaries that are depicted herein are the property of their respective owners. Excelitas reserves the right to change this document at any time without notice and disclaims liability for editorial, pictorial or typographical errors.